



G.P.T CO

Gol Pump Technology Company

Designed for light weight, excellent performance, low energy consumption, and easy maintenance, PRORIL submersible handy pumps serve a wide range of pumping applications on utility, construction, industrial, and municipal job sites.

60Hz

Handy and Residue Pump

SMART LITE 400

Handy Pump



SEMI VORTEX

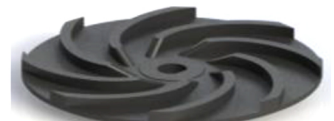



G.P.T CO

www.golpumps.com
www.golpumps.us

Hz 60

SMART LITE 400
Handy Pump

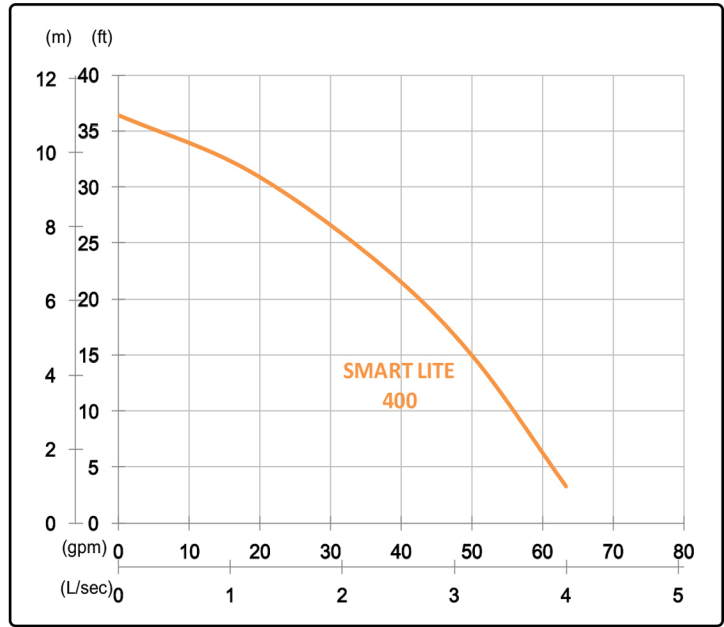

Shaft Speed : 3450 rpm

Outlet : 50mm, 2in

OUTPUT

HEAD

FLOW

0.4 kW

Rated : 7m, 23ft

Rated : 2.3 L/s, 37 gpm

0.5 HP

Max : 11m, 36ft

Max : 4 L/s, 63 gpm

Solid Passage : 7mm, 0.3in

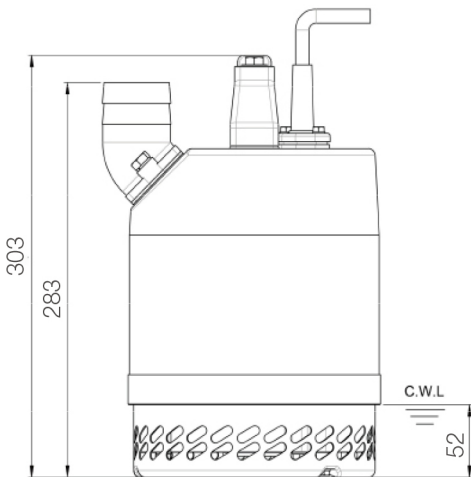
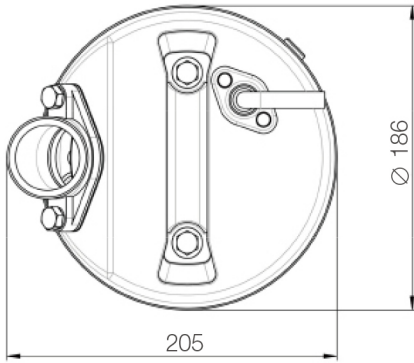

unit : mm

Weight : 11kg / 25 lbs

Pump Type		Electric Submersible Pumps
		1-Phase
Motor	Type	Induction Motor
	Poles	2 Pole
	Insulation	Class F
	Protector	Miniature Thermal Protector
	Starter	Capacitor-Run
Lubricant		Food Grade (ISO VG32)
Impeller Type		Semi-Vortex
Shaft Seal		Double Mechanical Seal
		Silicon Carbide VS Ceramic / Carbon
Bearings		C3 Shielded ball bearings
Cable		PVC (CSA Certified) / H07RN-F
		6m (20ft) or longer upon request.
Materials	Pump Casing	Gray Iron
	Impeller	Synthetic Polymers
	Motor Frame	Aluminum
	Motor Shaft	Stainless Steel
	Outer Case	Aluminum
	Strainer	Carbon Steel
Max. Liquid Temperature		40°C (104°F)
Max. Submersion Depth		20m (66ft)
pH Range		pH 5 - pH 8