



G.P.T CO

Gol Pump Technology Company

Designed for continuous operations, excellent performance and easy maintenance, PRORIL Tank series pumps have proven their reliability and durability in demanding areas like construction, mining, tunneling, quarries, industries and rental applications.

60Hz

OPENED

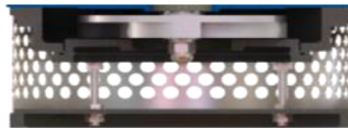

Dewatering Pump

TANK 215

High Chrome Dewatering Pump





G.P.T CO

www.golpumps.com
www.golpumps.us

Hz 60

TANK 215

High Chrome Dewatering Pump

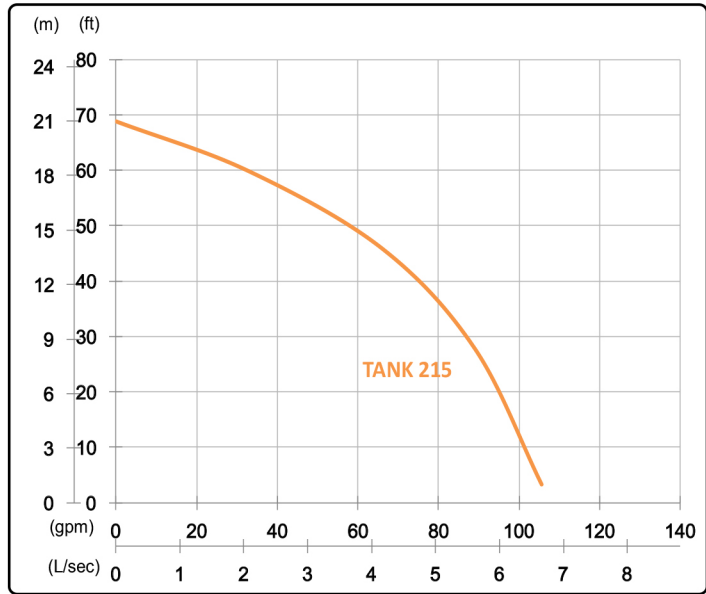

Shaft Speed :3450 rpm

Outlet : 50mm, 2in

OUTPUT	HEAD	FLOW
1.5 kW	Rated : 14m, 46ft	Rated : 4.2 L/s, 66 gpm
2 HP	Max : 21m, 69ft	Max : 6.7 L/s, 105 gpm
Solid Passage : 9mm, 0.4in		

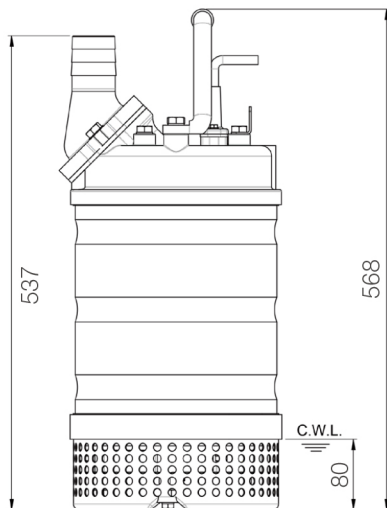
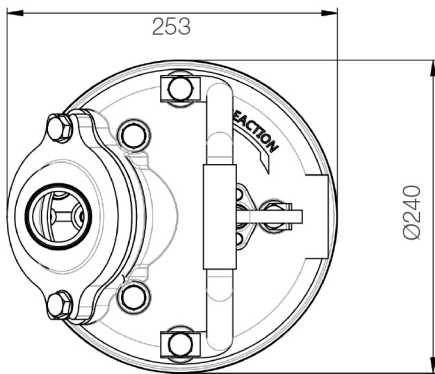

unit : mm

Weight : 33kg / 73 lbs

Pump Type		Electric Submersible Pumps
		1-Phase, 3-Phase
Motor	Type	Induction Motor
	Poles	2 Pole
	Insulation	Class F
	Protector	Circle Thermal Protector
Starter		1-Phase • Capacitor-Run, 3-Phase • D.O.L.
Lubricant		Food Grade (ISO VG32)
Impeller Type		Opened
Shaft Seal		Double Mechanical Seal
		Silicon Carbide VS Ceramic / Carbon
Bearings		C3 Shielded ball bearings
Cable		PVC (CSA Certified) / H07BQ-F
		10m (33ft) or longer upon request.
Materials	Pump Casing	Gray Iron
	Impeller	Chromium Iron
	Motor Frame	Stainless Steel
	Motor Shaft	Stainless Steel
	Strainer	Stainless Steel
Max. Liquid Temperature		40°C (104°F)
Max. Submersion Depth		20m (66ft)
pH Range		pH 5 - pH 8