



# G.P.T CO

Gol Pump Technology Company

Designed for continuous operations, excellent performance and easy maintenance, PRORIL Tank series pumps have proven their reliability and durability in demanding areas like construction, mining, tunneling, quarries, industries and rental applications.

60Hz

OPENED

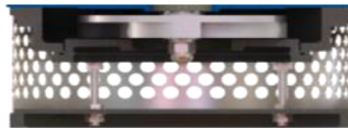

Dewatering Pump

## TANK 222

High Chrome Dewatering Pump





**G.P.T CO**

www.golpumps.com  
www.golpumps.us

Hz 60

## TANK 222

High Chrome Dewatering Pump

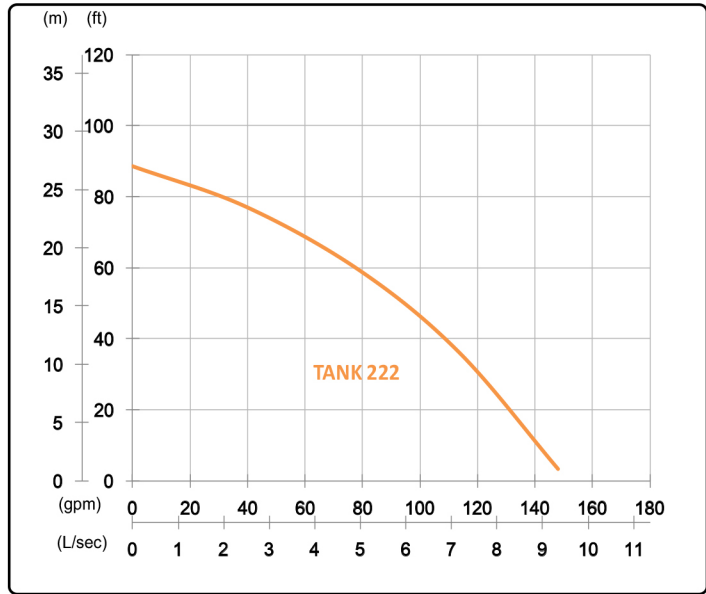

Shaft Speed : 3450 rpm

Outlet : 50mm, 2in

OUTPUT	HEAD	FLOW
2.2 kW	Rated : 18m, 59ft	Rated : 5 L/s, 79 gpm
3 HP	Max : 27m, 89ft	Max : 9.3 L/s, 148 gpm

Solid Passage : 9mm, 0.4in

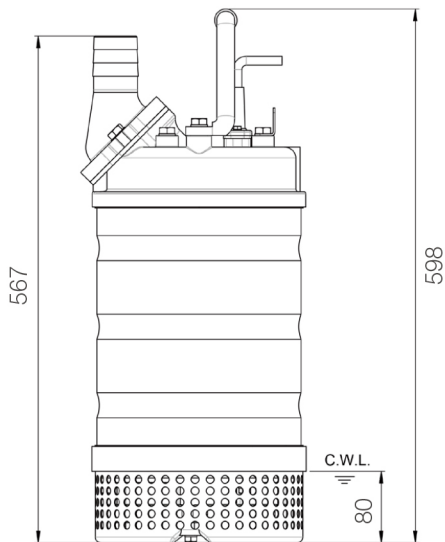
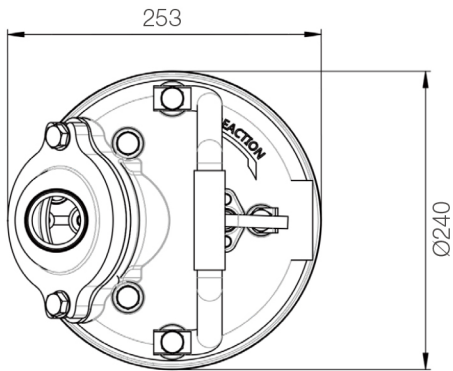

unit : mm

Weight : 35kg / 77 lbs

Pump Type		Electric Submersible Pumps
		3-Phase
Motor	Type	Induction Motor
	Poles	2 Pole
	Insulation	Class F
	Protector	Circle Thermal Protector
	Starter	D.O.L.
Lubricant		Food Grade (ISO VG32)
Impeller Type		Opened
Shaft Seal		Double Mechanical Seal
		Silicon Carbide VS Ceramic / Carbon
Bearings		C3 Shielded ball bearings
Cable		PVC (CSA Certified) / H07BQ-F
		10m (33ft) or longer upon request.
Materials	Pump Casing	Gray Iron
	Impeller	Chromium Iron
	Motor Frame	Stainless Steel
	Motor Shaft	Stainless Steel
	Strainer	Stainless Steel
Max. Liquid Temperature		40°C (104°F)
Max. Submersion Depth		20m (66ft)
pH Range		pH 5 - pH 8