



G.P.T CO

Gol Pump Technology Company

Designed for continuous operations, excellent performance and easy maintenance, PRORIL Tank series pumps have proven their reliability and durability in demanding areas like construction, mining, tunneling, quarries, industries and rental applications.

60Hz

OPENED

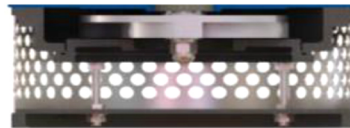

Dewatering Pump

TANK 3110

High Chrome Dewatering Pump





G.P.T CO

www.golpumps.com
www.golpumps.us

Hz 60



TANK 3110

High Chrome Dewatering Pump

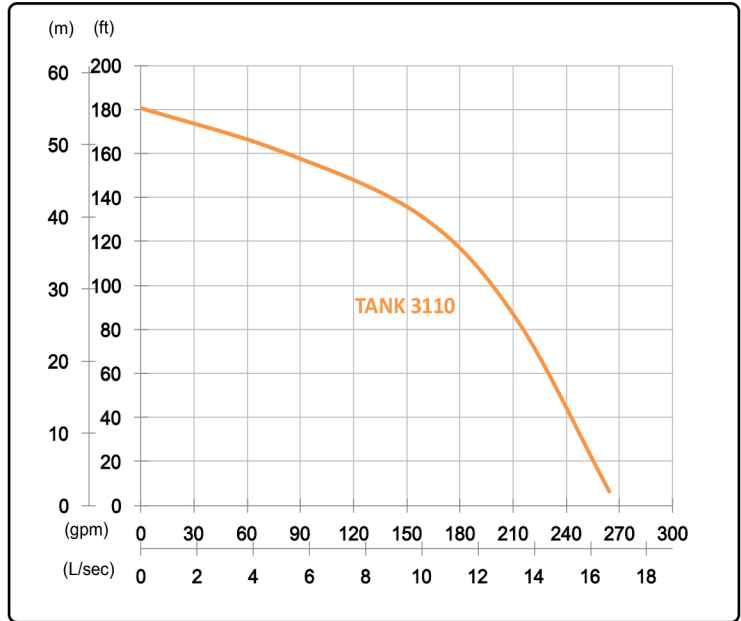

Shaft Speed : 3450 rpm

Outlet : 80mm, 3in

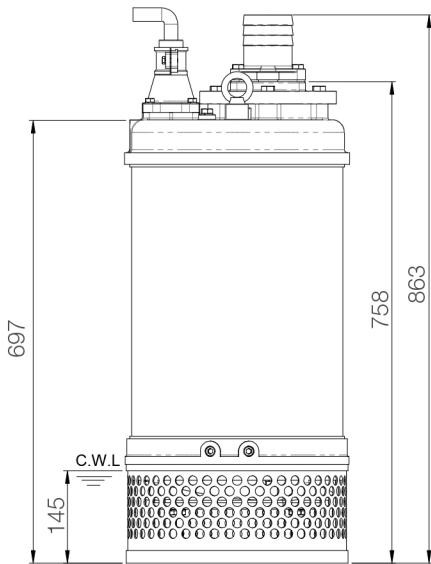
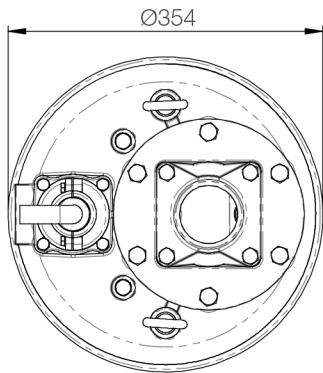

unit : mm

Weight : 135kg / 298 lbs

OUTPUT	HEAD	FLOW
11 kW	Rated : 40m, 131ft	Rated : 10 L/s, 158 gpm
15 HP	Max : 55m, 180ft	Max : 16.7 L/s, 264 gpm

Solid Passage : 10mm, 0.4in

Pump Type		Electric Submersible Pumps
		3-Phase
Motor	Type	Induction Motor
	Poles	2 Pole
	Insulation	Class F
	Protector	Circle Thermal Protector
	Starter	D.O.L.
Lubricant		Food Grade (ISO VG32)
Impeller Type		Opened
Shaft Seal		Double Mechanical Seal
		Silicon Carbide VS Ceramic / Carbon
Bearings		C3 Shielded ball bearings
Cable		PVC (CSA Certified) / H07BQ-F
		10m (33ft) or longer upon request.
Materials	Pump Casing	Gray Iron
	Impeller	Chromium Iron
	Motor Frame	Gray Iron
	Motor Shaft	Stainless Steel
	Strainer	Stainless Steel
Max. Liquid Temperature		40°C (104°F)
Max. Submersion Depth		20m (66ft)
pH Range		pH 5 - pH 8