



Technical Data

Vertical In-line Pump - EG100-8020-11004

Revision no.

Page:

1

Receiver

From

 Company name
 Respons. Department
 Person in charge
 Phone number
 Fax no
 E-mail address

 Brand: Gol Pumps
 Model: EG100-8020-11004

Motor (V1)	
Model	hp
Y2-160M-4	15

Weight (lb)		
Pump	Motor	Pump & motor
183	238	419

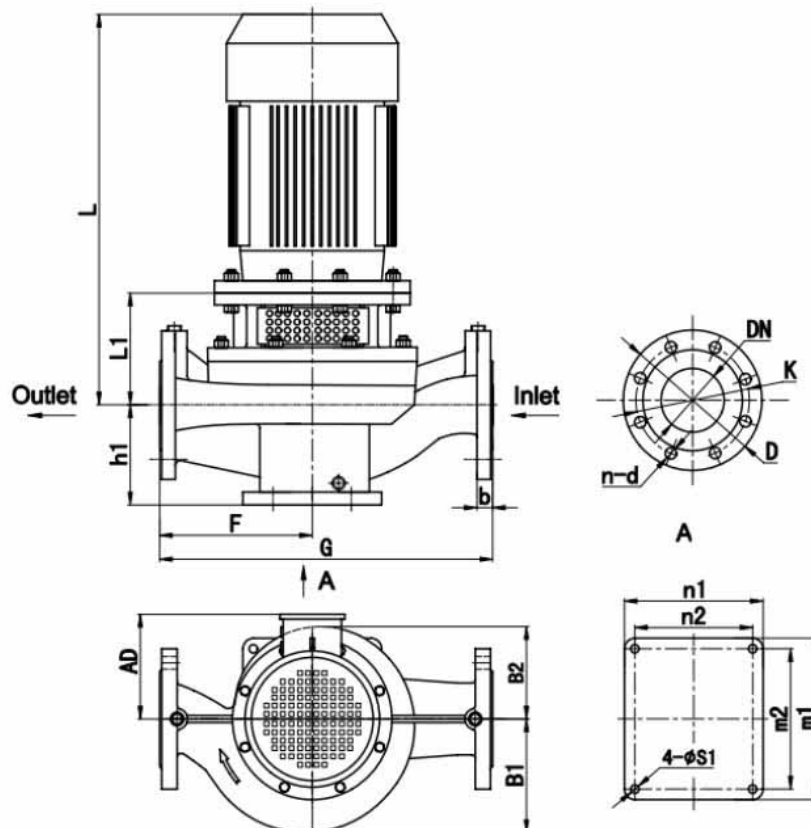
Dimensions:

Pump installation size (inch)

h1	L1	F	G	L	AD	B1	B2	n2 x m2	n1 x m1	s1	DN	D	K	n - d	b
7.4	9.2	11.4	23.6	28.7	10	7.6	6.5	6.7 x 7.9	7.9 x 9.1	0.6	3.9	8.7	7.1	8 - ϕ 18	0.9

Project

Project ID

Created by

Created on

Last update



Performance Curves

Vertical In-line Pump - EG100-8020-11004

Revision no. _____

Page: 2

Receiver	From

Company name
 Respons. Department
 Person in charge
 Phone number
 Fax no
 E-mail address

Model	Capacity			Head		Speed	Motor	Voltage	Phase	Impeller Diam.	
	m ³ /h	l/s	gpm	m	ft	r/min	hp	v		mm	inch
EG100-8020-11004	57	20	250.9	22.4	74	1750	10	460	3	214	8.4
	95	32	418.3	20.5	67.4		15				
	114	38.2	501.9	19.1	63		15				

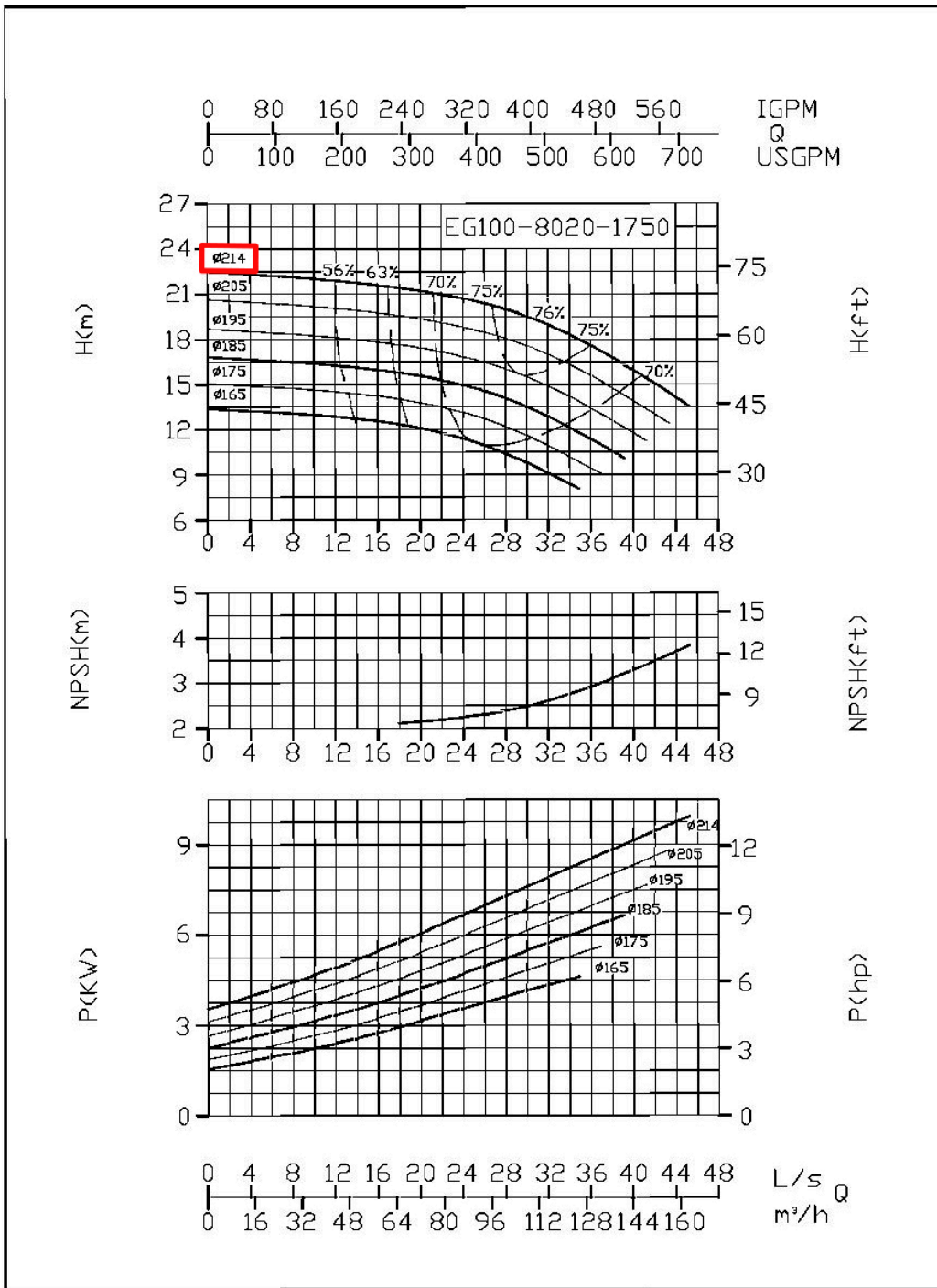

Project	Project ID	Created by	Created on	Last update
---------	------------	------------	------------	-------------