



Technical Data

Vertical In-line Pump - EG50-3220-11002

Revision no.

Page:
 1

Company name
 Respons. Department
 Person in charge
 Phone number
 Fax no
 E-mail address

Receiver

From



Brand: Gol Pumps
Model: EG50-3220-11002

Motor (V1)	
Model	hp
Y2-160M1-2	15

Weight (lb)		
Pump	Motor	Pump & motor
121	238	359

Dimensions:

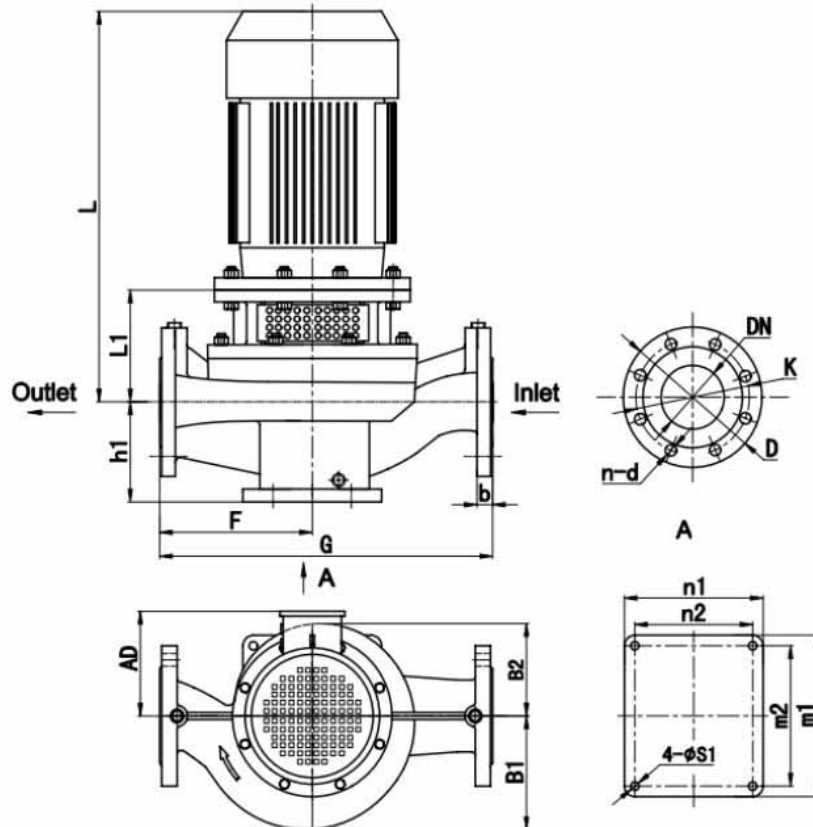

Pump installation size (inch)															
h1	L1	F	G	L	AD	B1	B2	n2 x m2	n1 x m1	s1	DN	D	K	n - d	b
4.6	8.6	8.3	16.5	28.5	10	5.4	5.3	6.7 x 7.9	7.9 x 9.1	0.6	6.5	4.9	5.7	4 - φ18	0.8

Project	Project ID	Created by	Created on	Last update
---------	------------	------------	------------	-------------



Performance Curves

Vertical In-line Pump - EG50-3220-11002

Revision no.

 Page:
2

Receiver

From

 Company name
 Respons. Department
 Person in charge
 Phone number
 Fax no
 E-mail address

Model	Capacity			Head		Speed	Motor	Voltage	Phase	Impeller Diam.	
	m ³ /h	l/s	gpm	m	ft	r/min	hp	v		mm	inch
EG50-3220-11002	11.3	4	49.8	68.8	225.5	3500	10	460	3	185	7.3
	18.8	6	82.8	61.9	203.1		15				
	22.5	7.2	99	55.6	182.5		15				

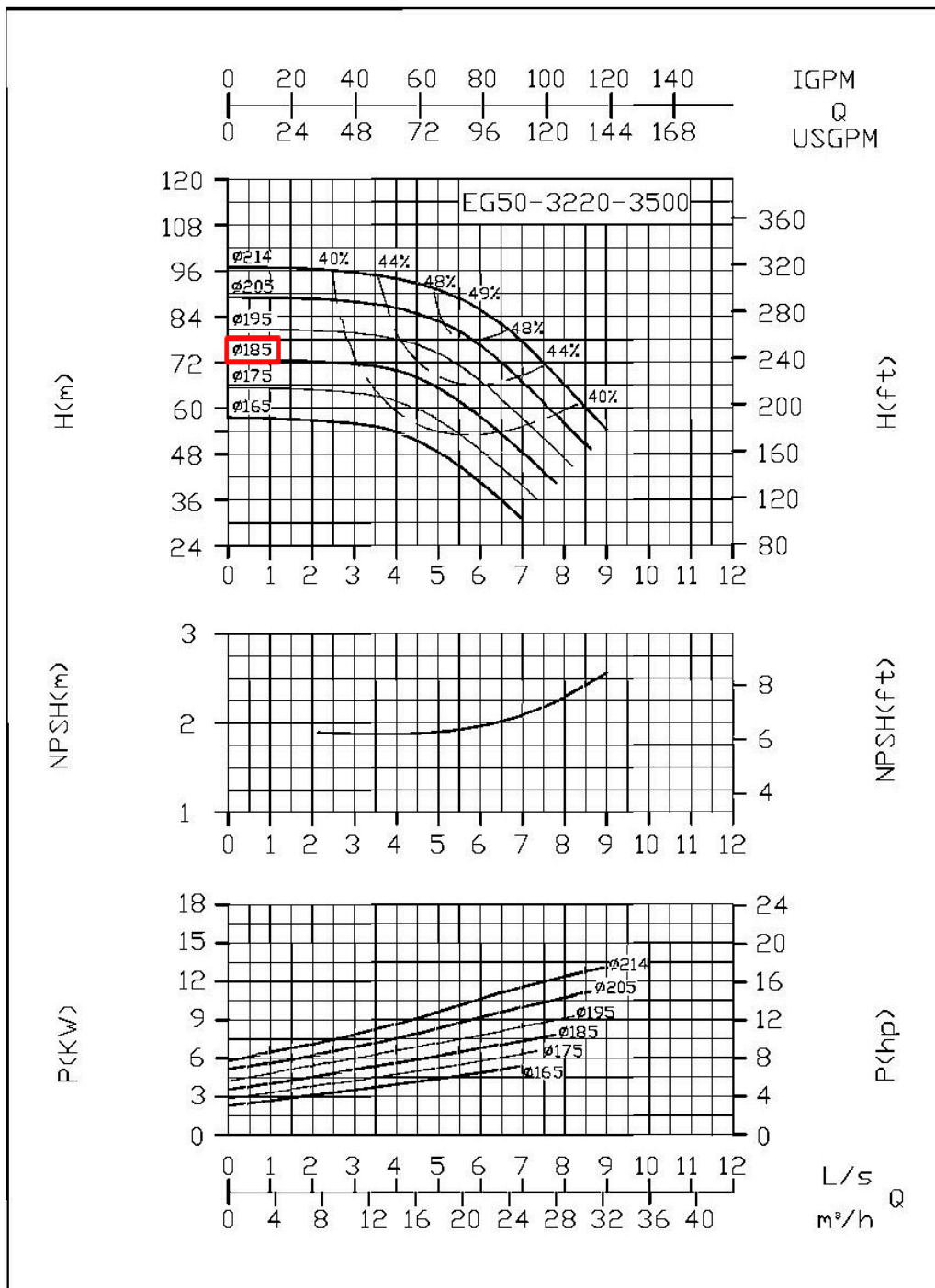

Project

Project ID

Created by

Created on

Last update