



Technical Data

Vertical In-line Pump - EG65-5020-04004

Revision no.

Page:
 1

Company name
 Respons. Department
 Person in charge
 Phone number
 Fax no
 E-mail address

Receiver

From



Brand: Gol Pumps
Model: EG65-5020-04004

Motor (V1)	
Model	hp
Y2-112M-4	5.5

Weight (lb)		
Pump	Motor	Pump & motor
119	104	220

Dimensions:

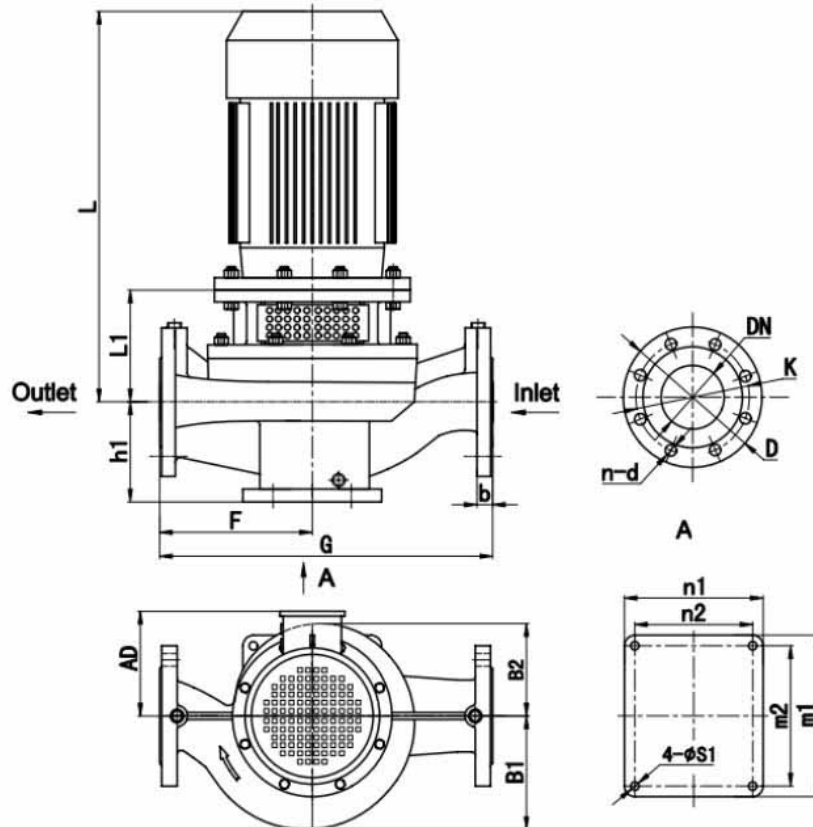

Pump installation size (inch)															
h1	L1	F	G	L	AD	B1	B2	n2 x m2	n1 x m1	s1	DN	D	K	n - d	b
5.4	6.5	9.4	18.9	19.9	7.5	6.2	5.6	6.7 x 7.9	7.9 x 9.1	0.6	2.6	7.3	5.7	4 - φ18	0.8

Project	Project ID	Created by	Created on	Last update
---------	------------	------------	------------	-------------



Performance Curves

Vertical In-line Pump - EG65-5020-04004

Revision no.

Page:
2

Receiver _____ From _____

Company name _____
 Respons. Department _____
 Person in charge _____
 Phone number _____
 Fax no _____
 E-mail address _____

Model	Capacity			Head		Speed	Motor	Voltage	Phase	Impeller Diam.	
	m ³ /h	l/s	gpm	m	ft	r/min	hp	v		mm	inch
EG65-5020-04004	18	6	79.3	22.3	73.1	1750	3	460	3	214	8.4
	30	10	132.1	19.4	63.5		4				
	36	12	158.5	17.2	56.4		5.5				

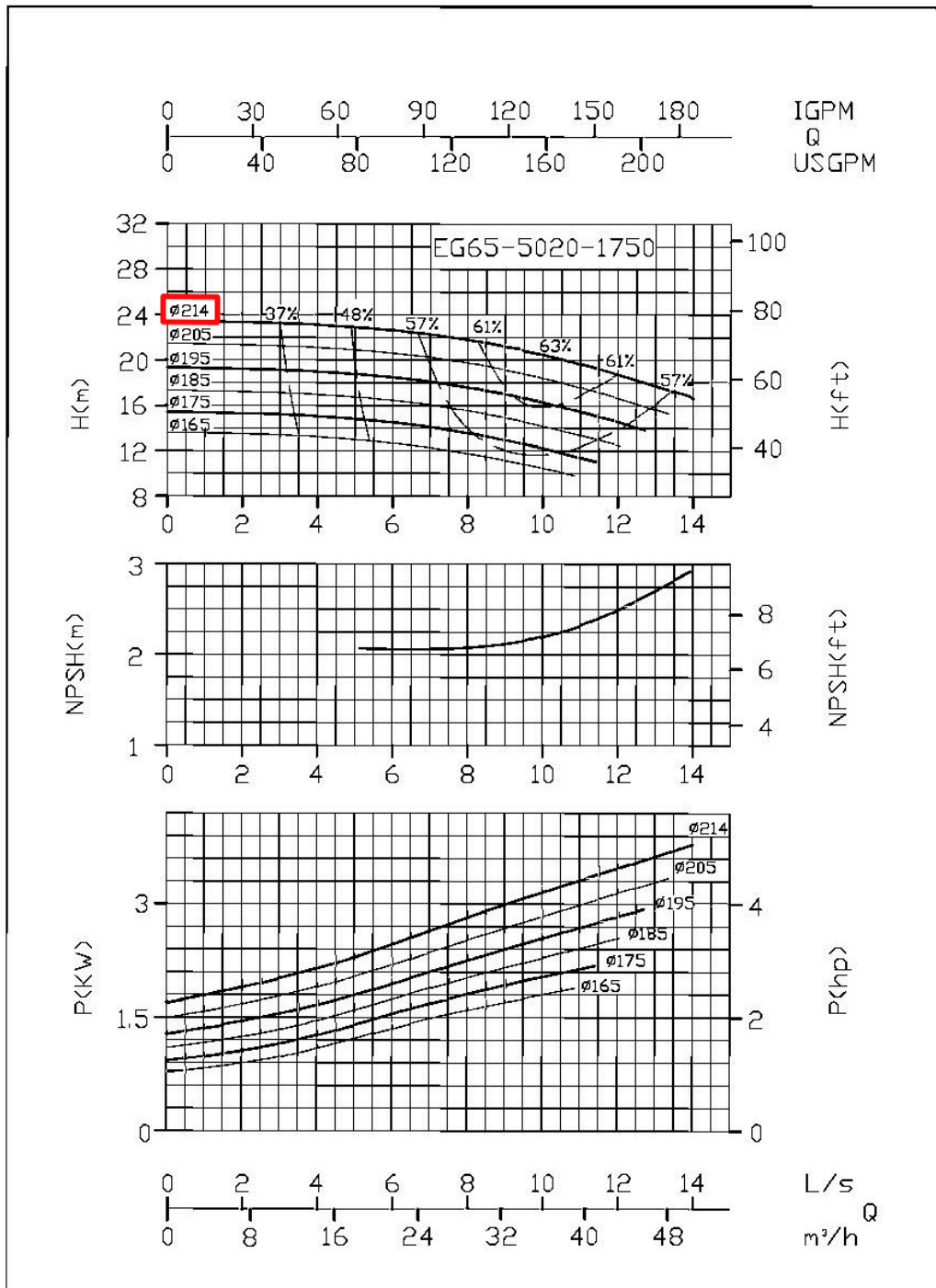

Project	Project ID	Created by	Created on	Last update
---------	------------	------------	------------	-------------