



# Technical Data

## Vertical In-line Pump - EGM100-8020-11004

Revision no.

Page:

1

Receiver

From

 Company name  
 Respons. Department  
 Person in charge  
 Phone number  
 Fax no  
 E-mail address





**Brand: Gol Pumps**  
**Model: EGM100-8020-11004**

Motor (V1)	
Model	HP
Y2-160M-4	15

Weight (lb)		
Pump	Motor	Pump & Motor
182.6	237.6	420.2

### Dimensions:

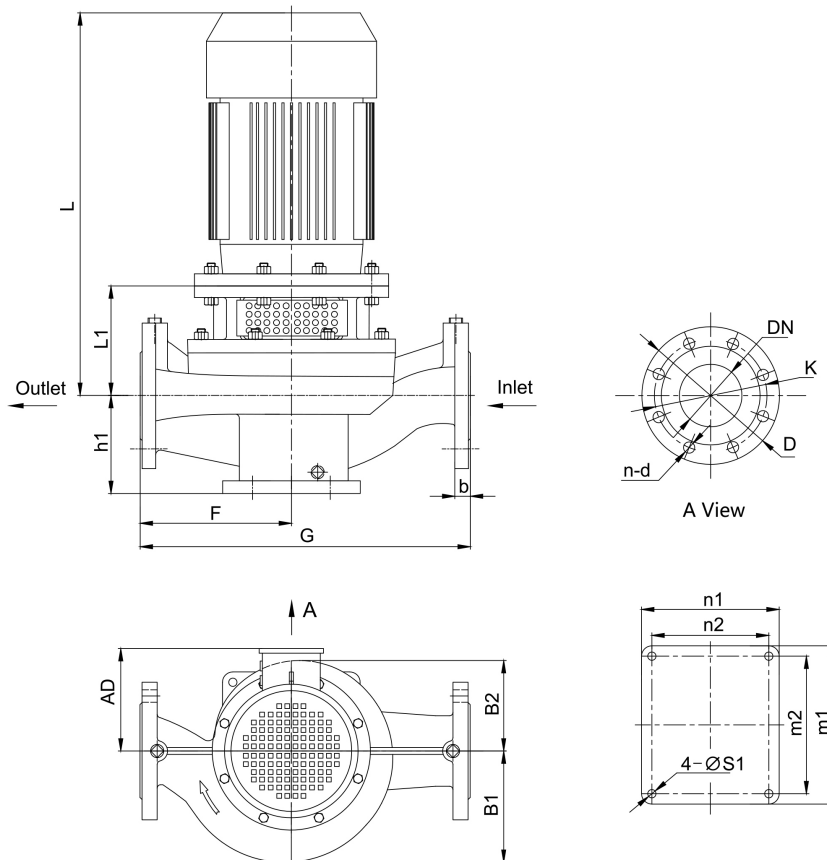

### Pump Installation Size (inch)

h1	L1	F	G	L	AD	B1	B2	n2 x m2	n1 x m1	S1	DN	D	K	n - d	b
7.4	9.2	11.4	23.6	28.7	10	7.6	6.5	6.7x7.9	7.9x9.1	0.6	4	8.9	7.5	8 - $\phi$ 0.8	-

Project

Project ID

Created by

Created on

Last update



# Performance Curves

## Vertical In-line Pump - EGM100-8020-11004

Revision no. \_\_\_\_\_  
 \_\_\_\_\_

Page:  
 2

Receiver	From

Company name  
 Respons. Department  
 Person in charge  
 Phone number  
 Fax no  
 E-mail address

Model	Capacity			Head		Speed	Motor	Voltage	Phase	Impeller Diam.		Eff.	(NPSH)r
	m <sup>3</sup> /h	l/s	gpm	m	ft	r/min	hp	v		mm	inch	%	ft
EGM100-8020-11004	77.8	21.6	342.4	22	72	1760	15	230/460	3	214	8.4	75	8.9
	129.6	36	570.6	19	62		15					84	12.5
	155.5	43.2	684.7	16.5	54		15					80	15.7

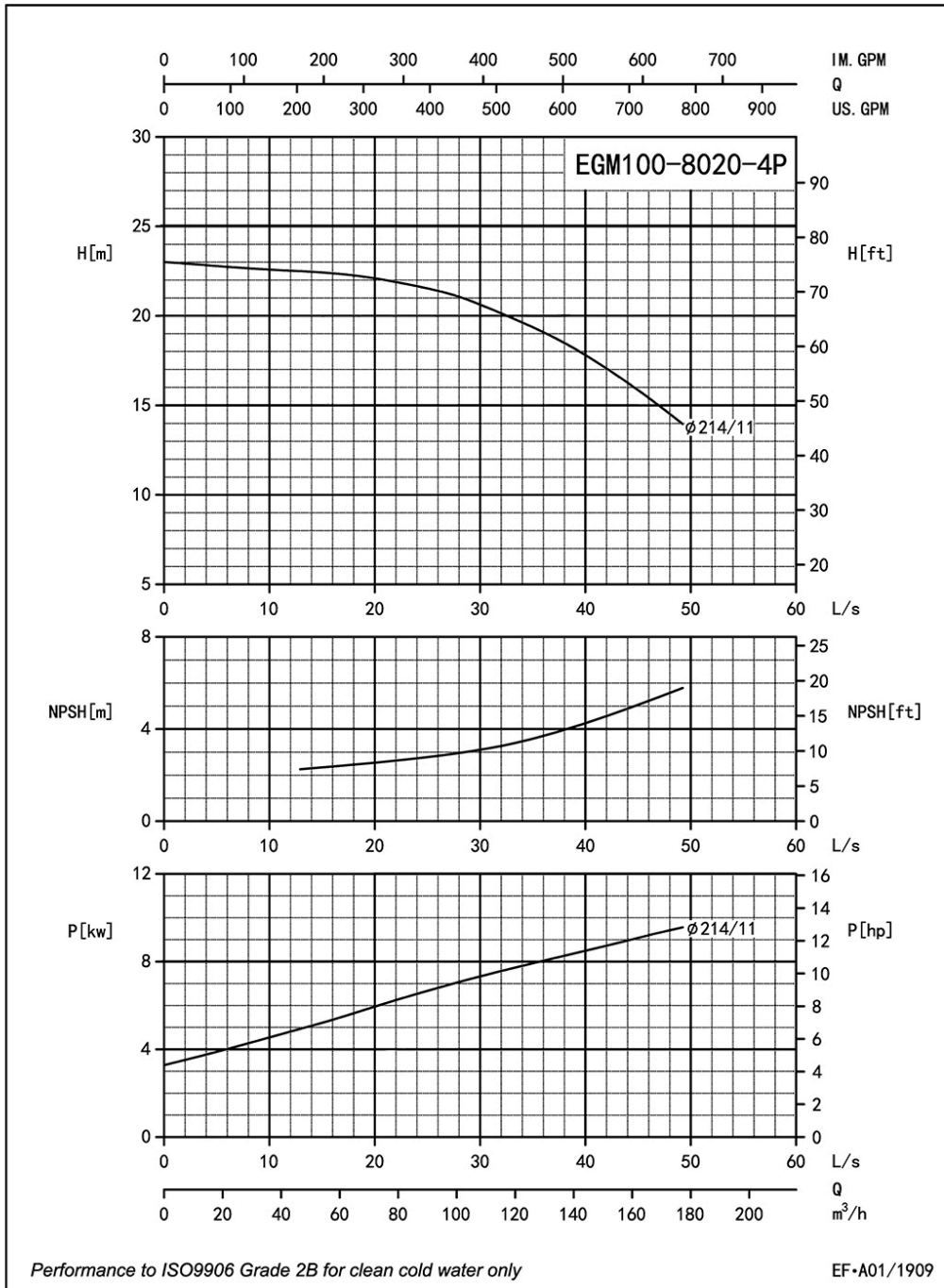

Project	Project ID	Created by	Created on	Last update
---------	------------	------------	------------	-------------



# Parts List

## Vertical In-line Pump - EGM100-8020-11004

Revision no.

Page:  
3

Receiver

From

Company name  
Respons. Department  
Person in charge  
Phone number  
Fax no  
E-mail address



### Parts List

1	Cassing	14	Screw
2	Impeller Nut	15	Screw Bolt
3	Flat Washer	16	Screw Nut
4	Spring Washer	17	Screw Bolt
5	Front-Wear Ring	18	1/4 Plug
6	Impeller	19	3/8 Plug
7	Seal Seat	20	Key
8	Mech Seal	21	Screw Nut
9	Casing Gasket	22	Motor
10	Casing Cover	23	Key
11	1/4 Plug	24	Screw
12	Adapter	25	Shaft
13	Guard		

Project	Project ID	Created by	Created on	Last update
---------	------------	------------	------------	-------------