



Technical Data

Vertical In-line Pump - EGM100-8026-15004

Revision no.

Page:
 1

Receiver	From

Company name
 Respons. Department
 Person in charge
 Phone number
 Fax no
 E-mail address



Brand: Gol Pumps
Model: EGM100-8026-15004

Motor (V1)	
Model	HP
Y2-160L-4	20

Weight (lb)		
Pump	Motor	Pump & Motor
217.8	283.8	501.6

Dimensions:

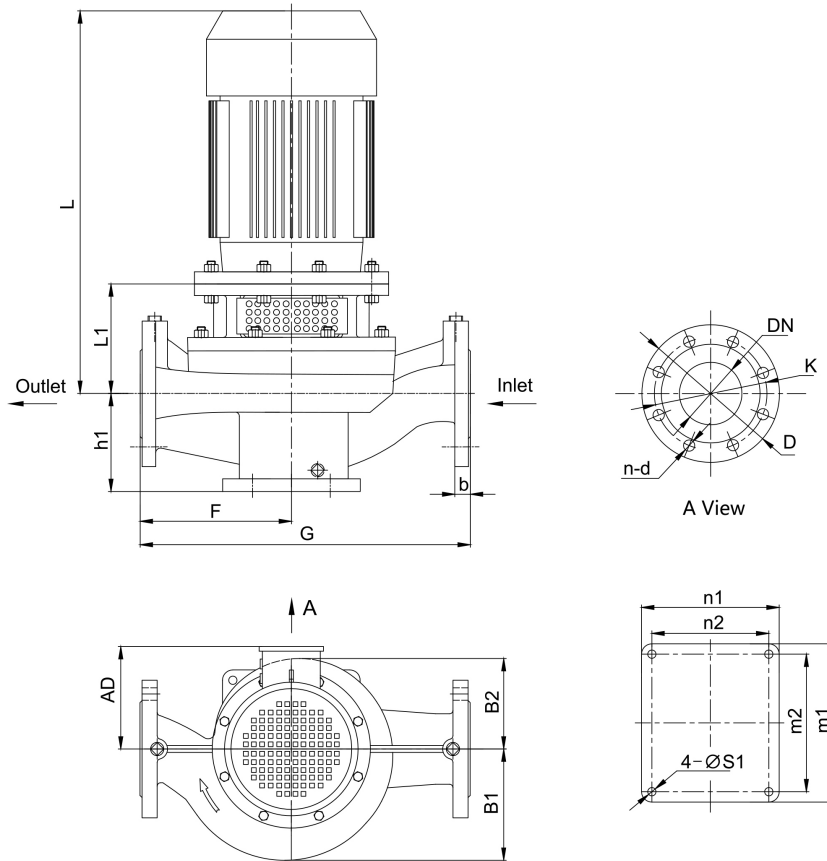

Pump Installation Size (inch)															
h1	L1	F	G	L	AD	B1	B2	n2 x m2	n1 x m1	S1	DN	D	K	n - d	b
7.4	9.2	12.2	24.8	31.3	10	8.2	7.2	6.7x7.9	7.9x9.1	0.6	4	8.9	7.5	8 - φ0.8	-

Project	Project ID	Created by	Created on	Last update
---------	------------	------------	------------	-------------



Performance Curves

Vertical In-line Pump - EGM100-8026-15004

Revision no.

Page:

2

Receiver

From

 Company name
 Respons. Department
 Person in charge
 Phone number
 Fax no
 E-mail address

Model	Capacity			Head		Speed	Motor	Voltage	Phase	Impeller Diam.		Eff.	(NPSH)r
	m ³ /h	l/s	gpm	m	ft	r/min	hp	v		mm	inch	%	ft
EGM100-8026-15004	71.3	19.8	313.8	32	105	1760	20	230/460	3	255	10	68	8.9
	118.8	33	523.1	28	92		20					77	11.2
	142.6	39.6	627.7	25	82		20					74	13.1

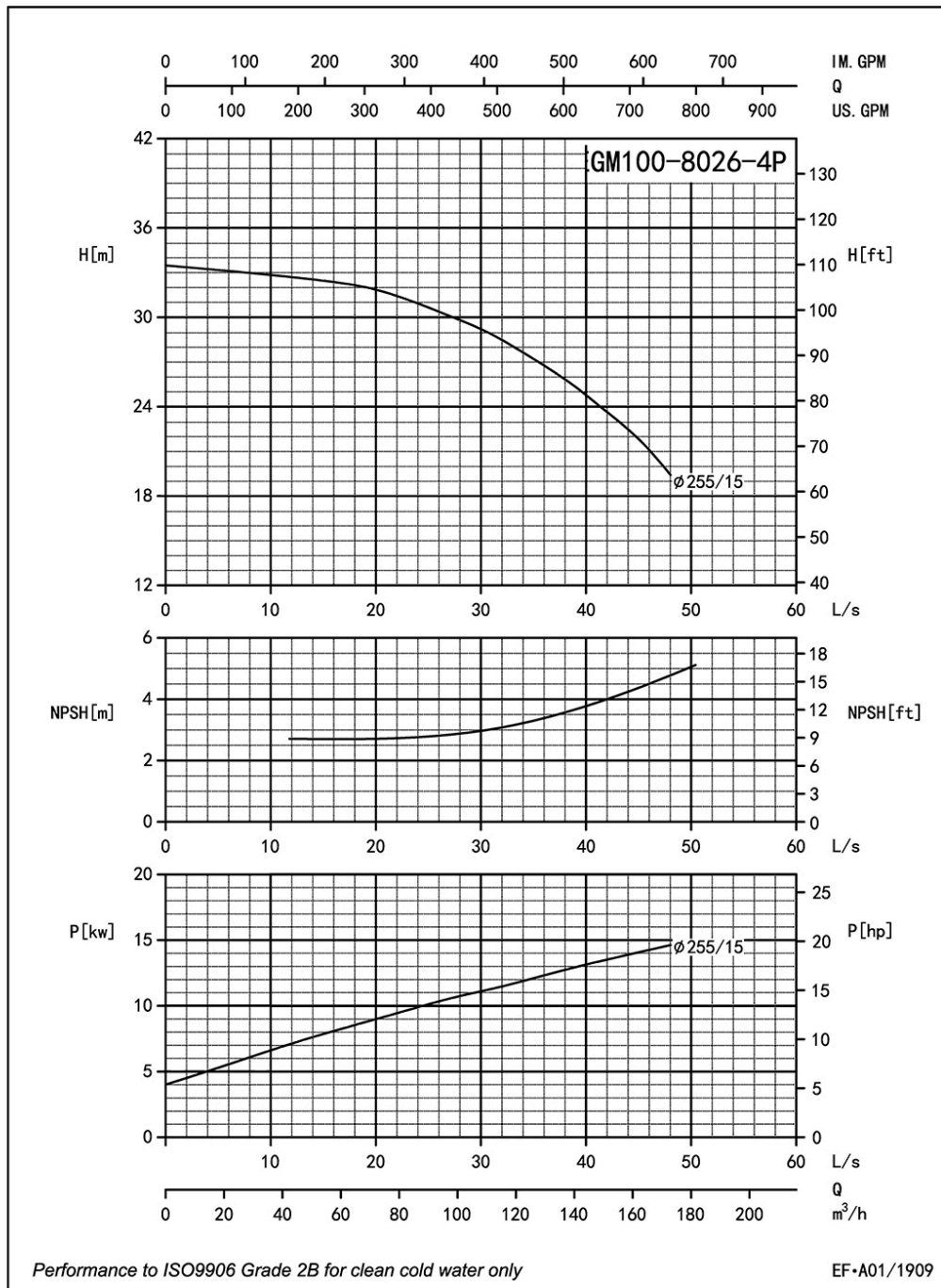

Project

Project ID

Created by

Created on

Last update



Parts List

Vertical In-line Pump - EGM100-8026-15004

Revision no.

Page:
 3

Receiver

From

Company name
 Respons. Department
 Person in charge
 Phone number
 Fax no
 E-mail address

Parts List

1 Casing	14 Screw
2 Impeller Nut	15 Screw Bolt
3 Flat Washer	16 Screw Nut
4 Spring Washer	17 Screw Bolt
5 Front-Wear Ring	18 1/4 Plug
6 Impeller	19 3/8 Plug
7 Seal Seat	20 Key
8 Mech Seal	21 Screw Nut
9 Casing Gasket	22 Motor
10 Casing Cover	23 Key
11 1/4 Plug	24 Screw
12 Adapter	25 Shaft
13 Guard	

Project	Project ID	Created by	Created on	Last update
---------	------------	------------	------------	-------------