



Technical Data

Vertical In-line Pump - EGM65-4020-02204

Revision no.

Page:
 1

	Receiver	From
Company name		
Respons. Department		
Person in charge		
Phone number		
Fax no		
E-mail address		



Brand: Gol Pumps
Model: EGM65-4020-02204

Motor (V1)	
Model	HP
Y2-100L1-4	3

Weight (lb)		
Pump	Motor	Pump & Motor
114.4	74.8	189.2

Dimensions:

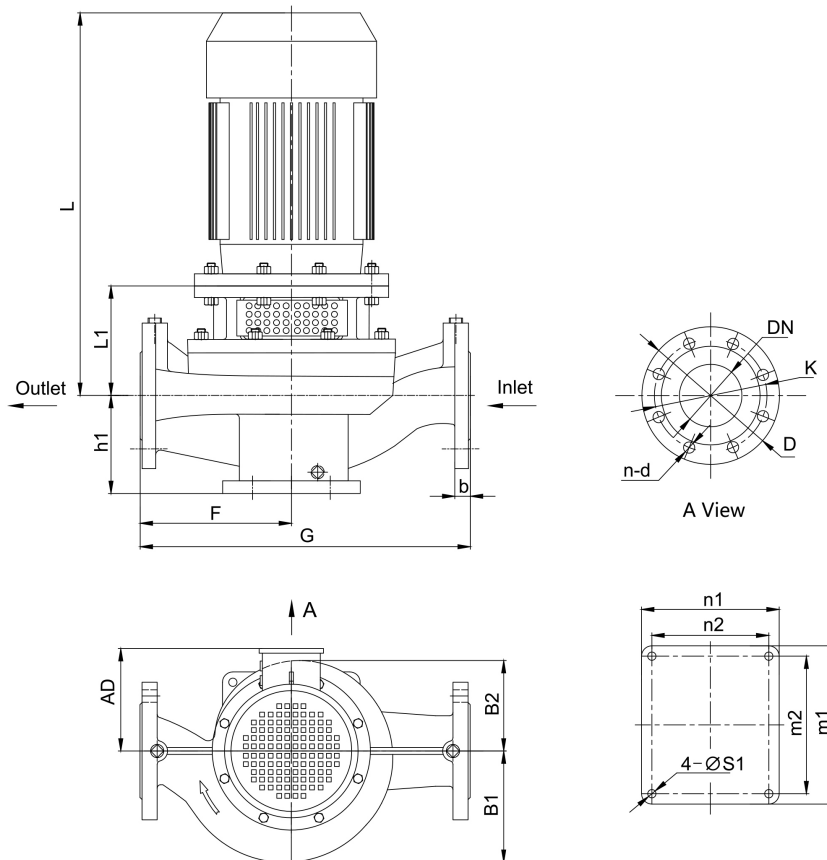

Pump Installation Size (inch)															
h1	L1	F	G	L	AD	B1	B2	n2 x m2	n1 x m1	S1	DN	D	K	n - d	b
5.4	6.4	9.4	18.9	19.2	7.1	5.7	5.3	6.7x7.9	7.9x9.1	0.6	2.5	6.9	5.5	4 - ϕ 0.8	-

Project	Project ID	Created by	Created on	Last update
---------	------------	------------	------------	-------------



Performance Curves

Vertical In-line Pump - EGM65-4020-02204

Revision no. _____
Page: 2

Receiver	From

Company name
Respons. Department
Person in charge
Phone number
Fax no
E-mail address

Model	Capacity			Head		Speed r/min	Motor hp	Voltage v	Phase	Impeller Diam.		Eff. %	(NPSH)r ft
	m ³ /h	l/s	gpm	m	ft					mm	inch		
EGM65-4020-02204	12.6	3.5	55.2	19.6	64	1710	3	230/460	3	214	8.4	49	7.5
	20.9	5.8	91.9	17.5	57		3					58	9.8
	25.2	7	110.3	15.4	51		3					55	11.5

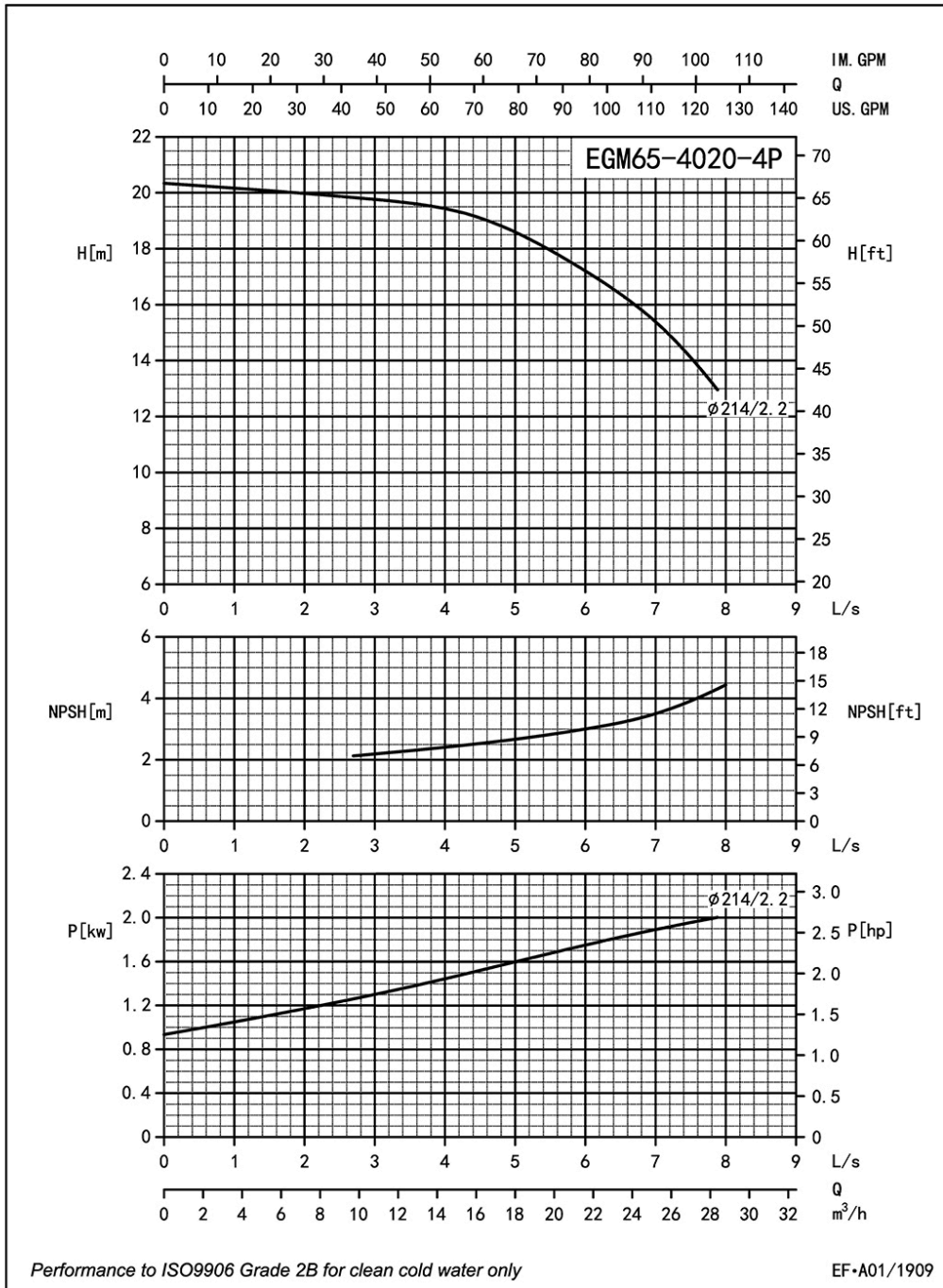

Project	Project ID	Created by	Created on	Last update
---------	------------	------------	------------	-------------



Parts List

Vertical In-line Pump - EGM65-4020-02204

Revision no.

Page:

3

Receiver

From

 Company name
 Respons. Department
 Person in charge
 Phone number
 Fax no
 E-mail address

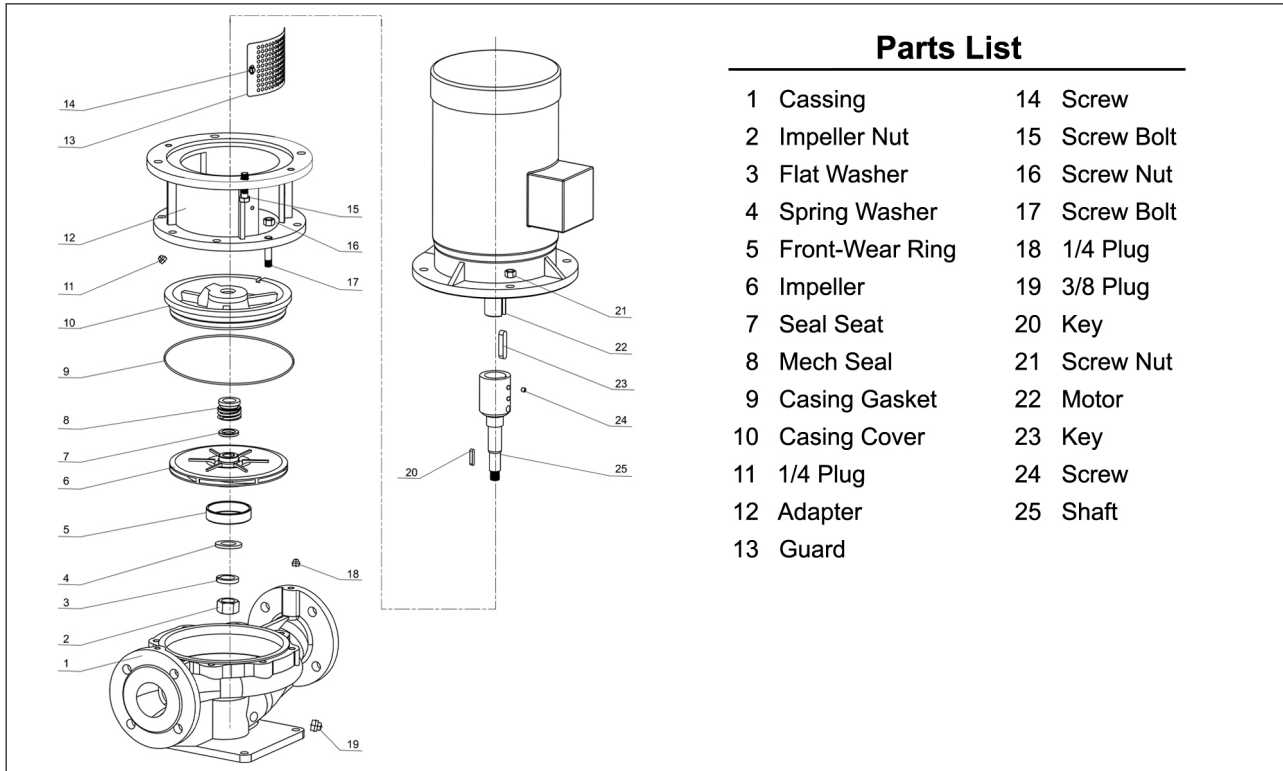

Project

Project ID

Created by

Created on

Last update