



# Technical Data

## Vertical In-line Pump - EGM65-5016-02204

Revision no.

Page:  
 1

Company name  
 Respons. Department  
 Person in charge  
 Phone number  
 Fax no  
 E-mail address

Receiver

From





**Brand: Gol Pumps**  
**Model: EGM65-5016-02204**

Motor (V1)	
Model	HP
Y2-100L1-4	3

Weight (lb)		
Pump	Motor	Pump & Motor
101.2	74.8	176

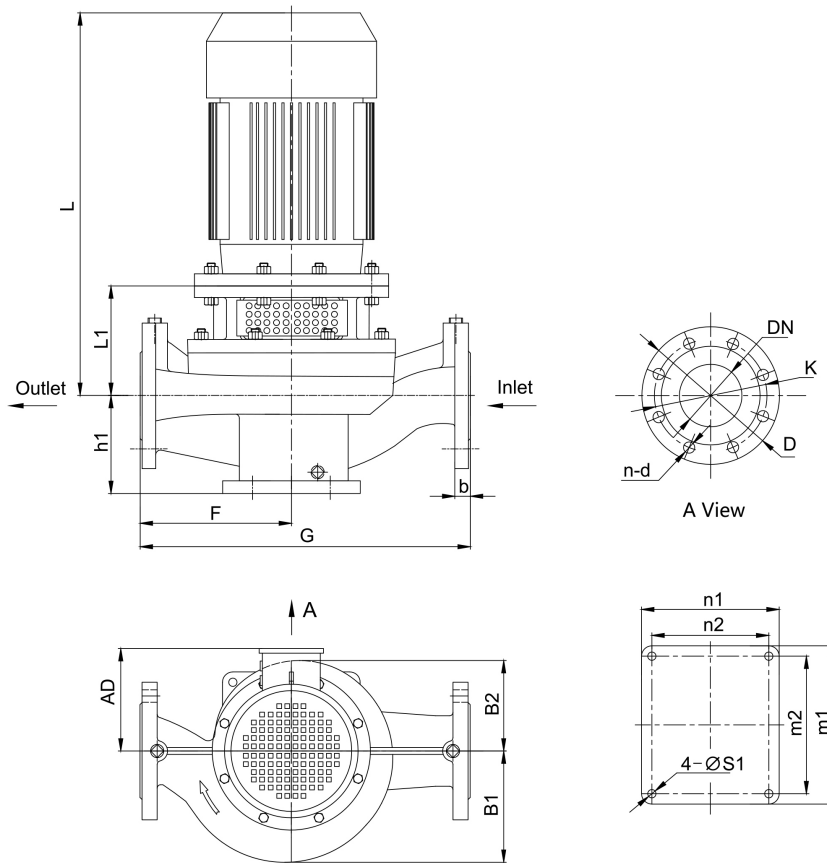
**Dimensions:**



Pump Installation Size (inch)															
h1	L1	F	G	L	AD	B1	B2	n2 x m2	n1 x m1	S1	DN	D	K	n - d	b
5.4	6.5	8.7	17.3	19.3	7.1	5.5	4.7	6.7x7.9	7.9x9.1	0.5	2.5	6.9	5.5	4 - φ0.8	-

Project	Project ID	Created by	Created on	Last update
---------	------------	------------	------------	-------------



# Performance Curves

## Vertical In-line Pump - EGM65-5016-02204

Revision no.

 Page:  
2

Receiver

From

 Company name  
 Respons. Department  
 Person in charge  
 Phone number  
 Fax no  
 E-mail address

Model	Capacity			Head		Speed	Motor	Voltage	Phase	Impeller Diam.		Eff.	(NPSH)r
	m <sup>3</sup> /h	l/s	gpm	m	ft	r/min	hp	v		mm	inch	%	ft
EGM65-5016-02204	24.5	6.8	107.5	12.8	42	1710	3	230/460	3	165	6.5	65	7.5
	40.7	11.3	179.1	11.5	38		3					74	10.8
	49	13.6	214.9	10	33		3					69	14.8

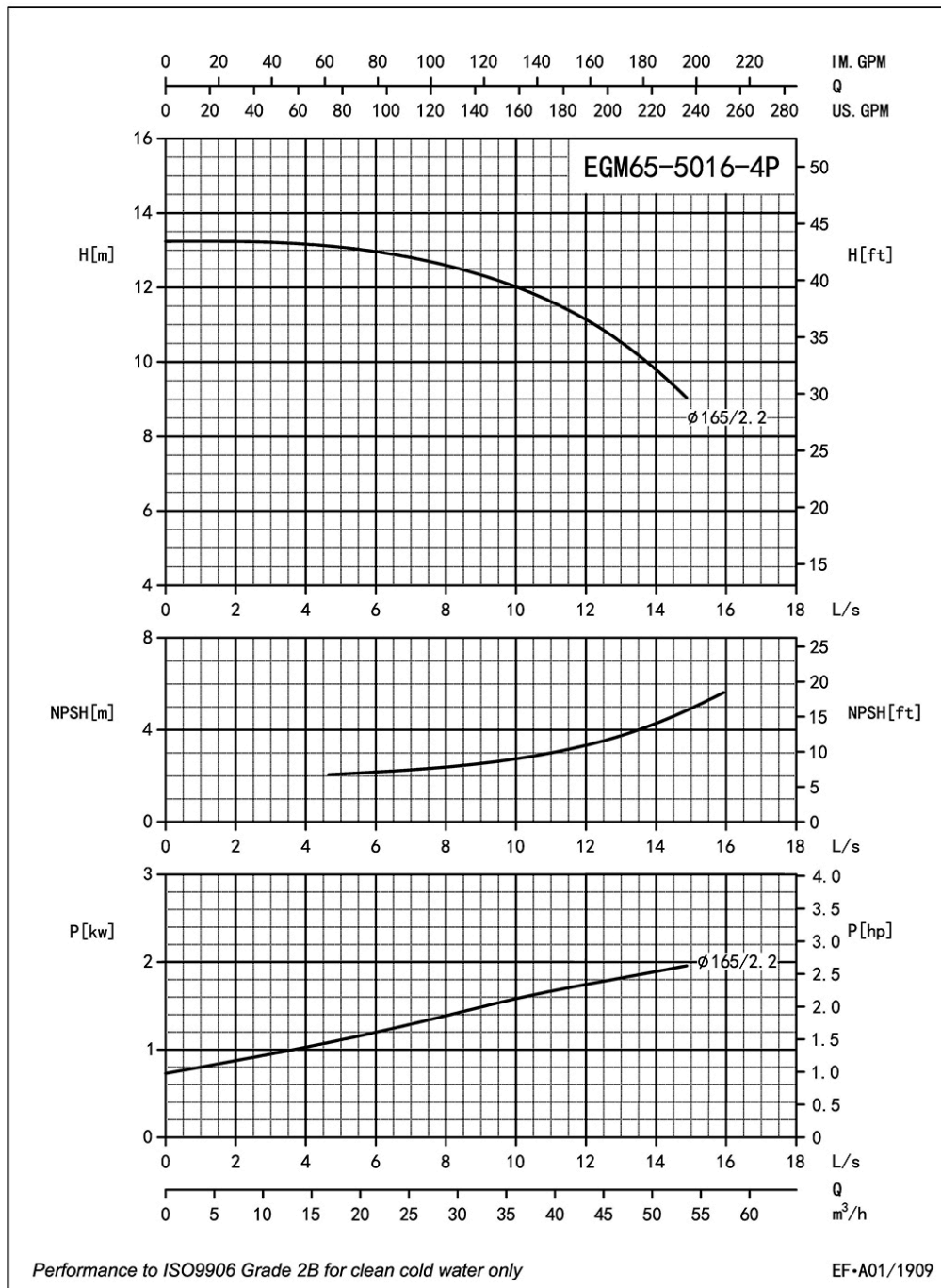

Project

Project ID

Created by

Created on

Last update



# Parts List

## Vertical In-line Pump - EGM65-5016-02204

Revision no.

Page:

3

Receiver

From

 Company name  
 Respons. Department  
 Person in charge  
 Phone number  
 Fax no  
 E-mail address

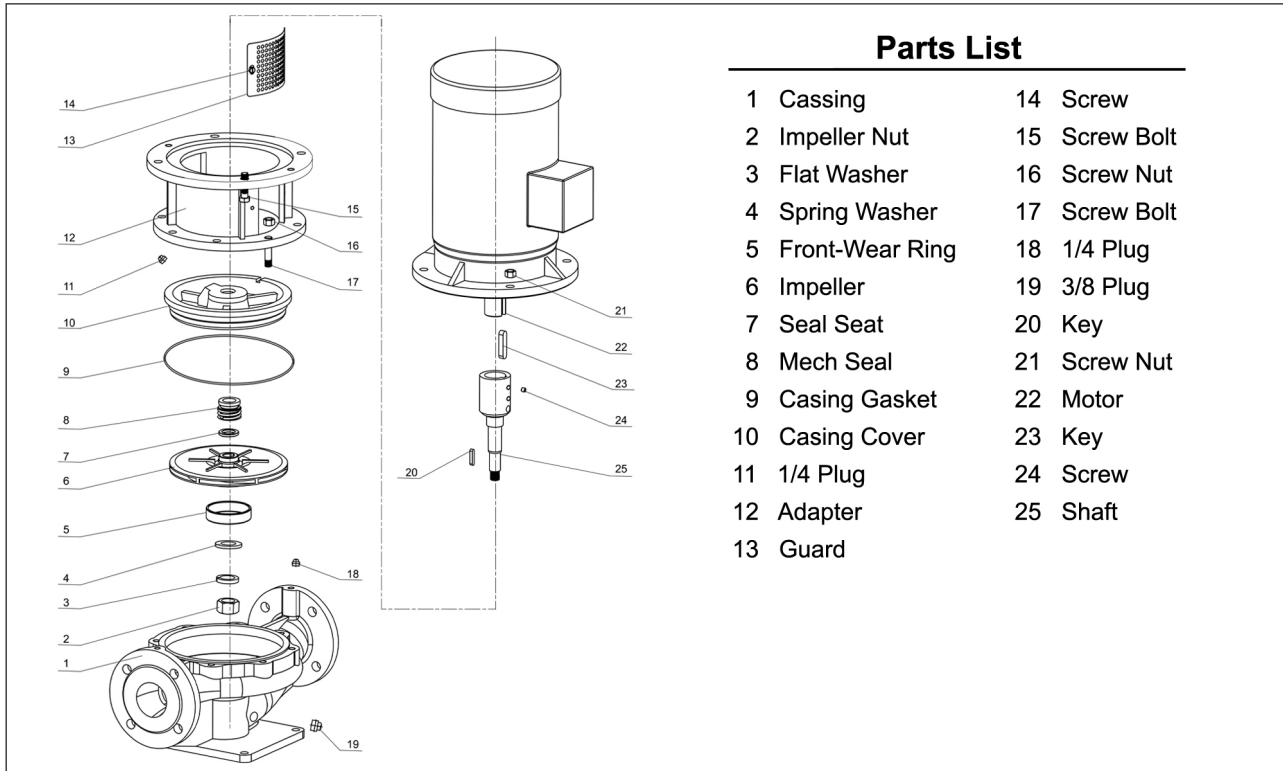
Project

Project ID

Created by

Created on

Last update