



# Technical Data

## Vertical In-line Pump - EGM65-5020-02204

Revision no.

Page:

1

Receiver

From

 Company name  
 Respons. Department  
 Person in charge  
 Phone number  
 Fax no  
 E-mail address

--	--



**Brand: Gol Pumps**  
**Model: EGM65-5020-02204**

Motor (V1)	
Model	HP
Y2-100L1-4	3

Weight (lb)		
Pump	Motor	Pump & Motor
118.8	74.8	191.4

### Dimensions:

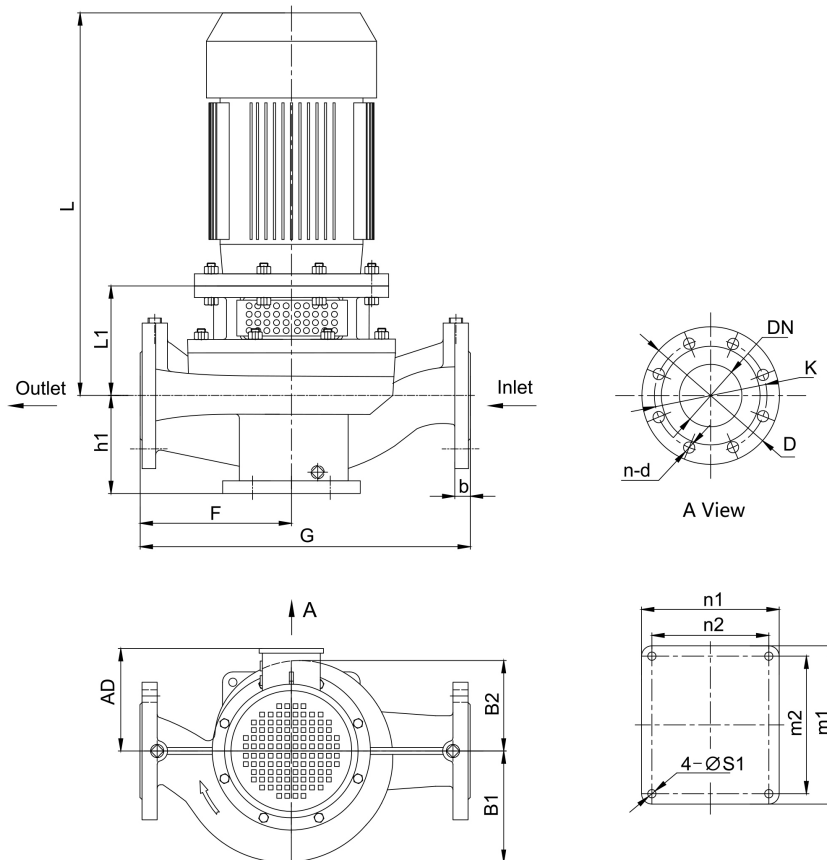

### Pump Installation Size (inch)

h1	L1	F	G	L	AD	B1	B2	n2 x m2	n1 x m1	S1	DN	D	K	n - d	b
5.4	6.5	9.4	18.9	19.7	7.1	6.2	5.6	6.7x7.9	7.9x9.1	0.6	2.5	6.9	5.5	4 - $\phi$ 0.8	-

Project

Project ID

Created by

Created on

Last update



# Performance Curves

## Vertical In-line Pump - EGM65-5020-02204

Revision no.

Page:

2

Receiver

From

 Company name  
 Respons. Department  
 Person in charge  
 Phone number  
 Fax no  
 E-mail address

Model	Capacity			Head		Speed	Motor	Voltage	Phase	Impeller Diam.		Eff.	(NPSH)r
	m <sup>3</sup> /h	l/s	gpm	m	ft	r/min	hp	v		mm	inch	%	ft
EGM65-5020-02204	19.4	5.4	85.6	14.5	48	1710	3	230/460	3	175	6.9	55	5.2
	32.4	9	142.7	12	39		3					63	7.5
	38.9	10.8	171.2	10.1	33		3					59	9.8

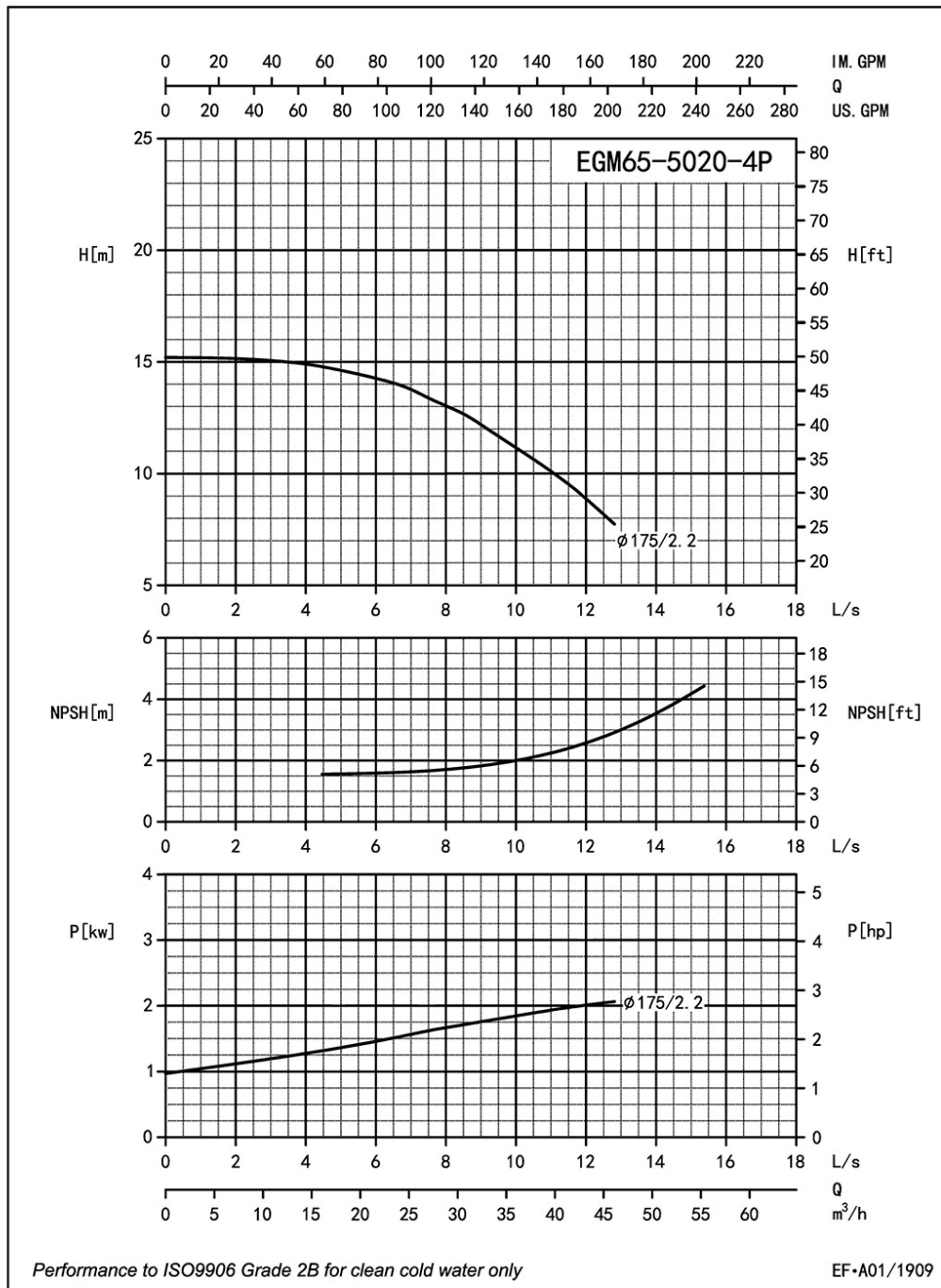

Project

Project ID

Created by

Created on

Last update



# Parts List

## Vertical In-line Pump - EGM65-5020-02204

Revision no.

Page:

3

Receiver

From

 Company name  
 Respons. Department  
 Person in charge  
 Phone number  
 Fax no  
 E-mail address



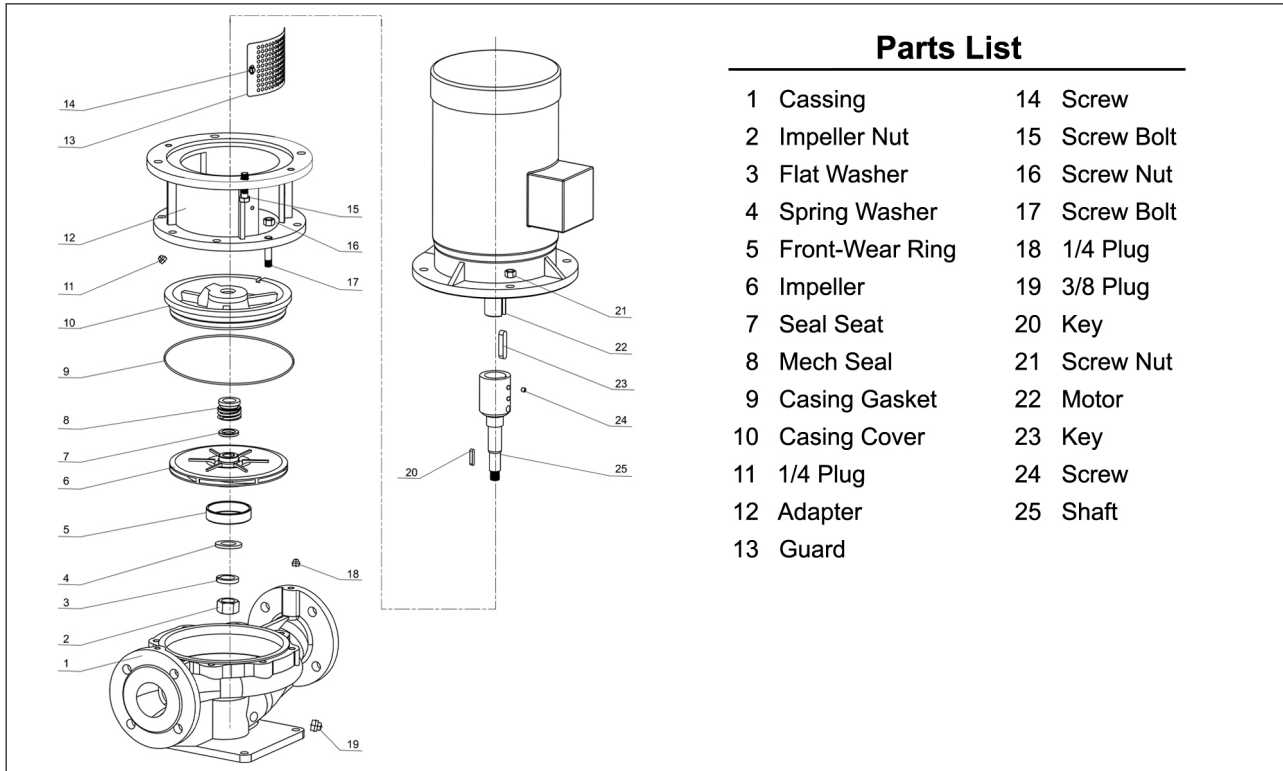

Project

Project ID

Created by

Created on

Last update