



Technical Data

Vertical In-line Pump - EGM65-5020-03004

Revision no.

Page:
 1

Company name
 Respons. Department
 Person in charge
 Phone number
 Fax no
 E-mail address

Receiver

From



Brand: Gol Pumps
Model: EGM65-5020-03004

Motor (V1)	
Model	HP
Y2-100L2-4	4

Weight (lb)		
Pump	Motor	Pump & Motor
118.8	81.4	198

Dimensions:

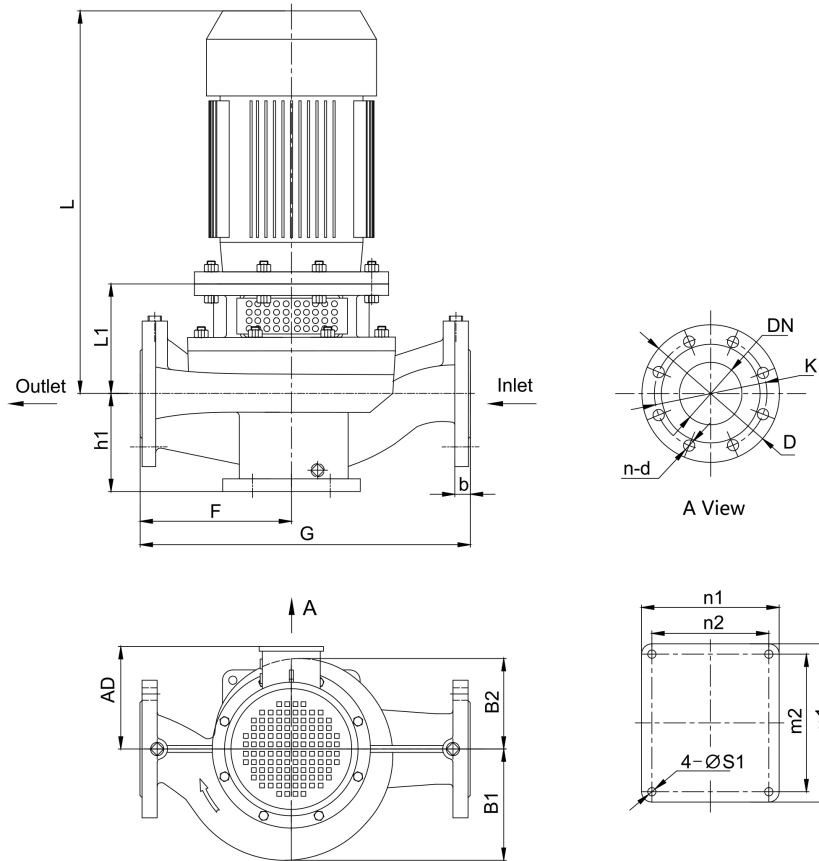

Pump Installation Size (inch)															
h1	L1	F	G	L	AD	B1	B2	n2 x m2	n1 x m1	S1	DN	D	K	n - d	b
5.4	6.5	9.4	18.9	19.7	7.1	6.2	5.6	6.7x7.9	7.9x9.1	0.6	2.5	6.9	5.5	4 - φ0.8	-

Project	Project ID	Created by	Created on	Last update
---------	------------	------------	------------	-------------



Performance Curves

Vertical In-line Pump - EGM65-5020-03004

Revision no.

Page:

2

Receiver

From

 Company name
 Respons. Department
 Person in charge
 Phone number
 Fax no
 E-mail address

Model	Capacity			Head		Speed	Motor	Voltage	Phase	Impeller Diam.		Eff.	(NPSH)r
	m ³ /h	l/s	gpm	m	ft	r/min	hp	v		mm	inch	%	ft
EGM65-5020-03004	22	6.1	97	17.7	58	1710	4	230/460	3	195	7.7	58	5.2
	36.7	10.2	161.7	15	49		4					65	7.5
	43.9	12.2	194	13.1	43		4					62	9.8

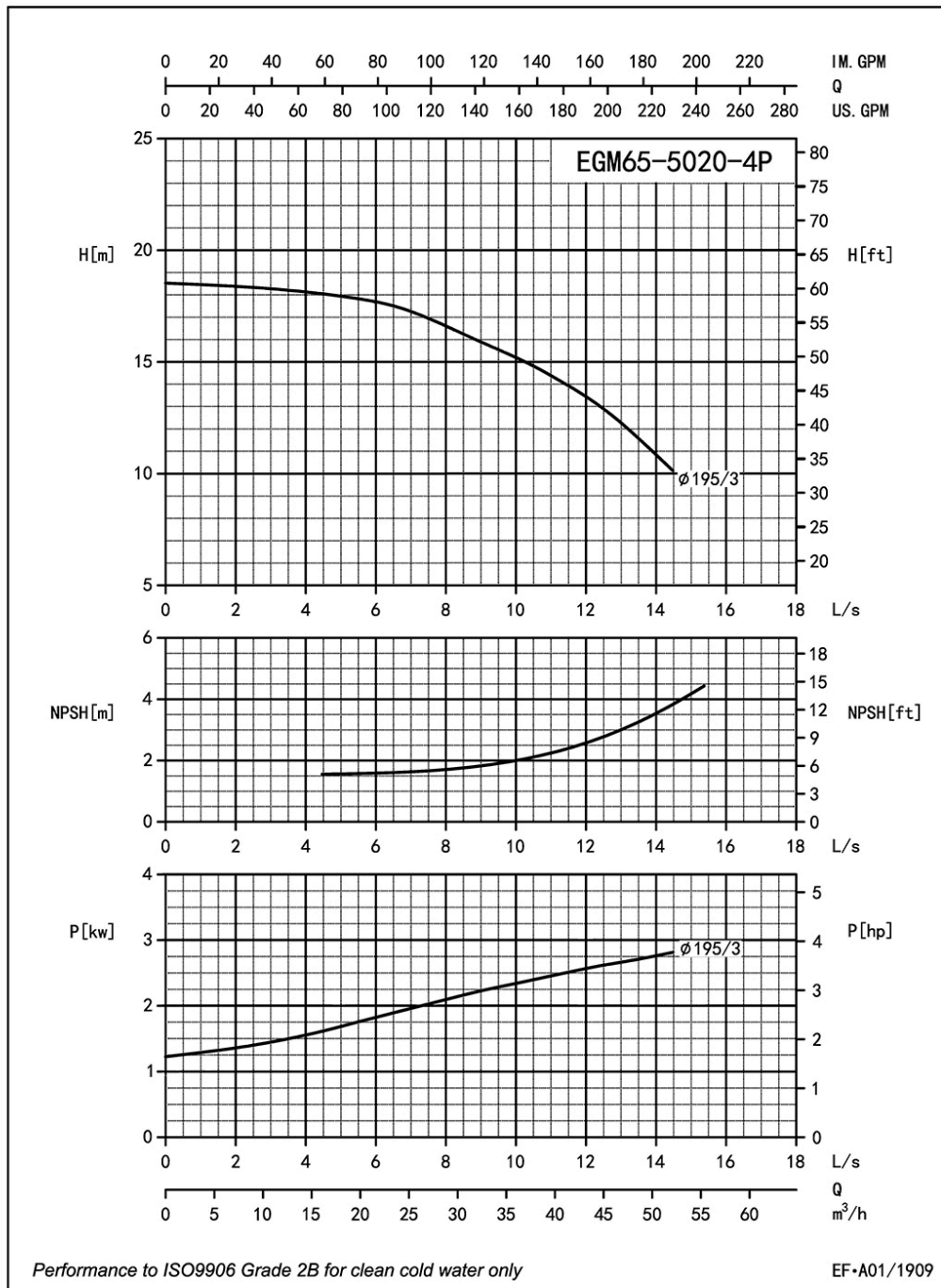

Project

Project ID

Created by

Created on

Last update



Parts List

Vertical In-line Pump - EGM65-5020-03004

Revision no.

Page:

3

Receiver

From

 Company name
 Respons. Department
 Person in charge
 Phone number
 Fax no
 E-mail address

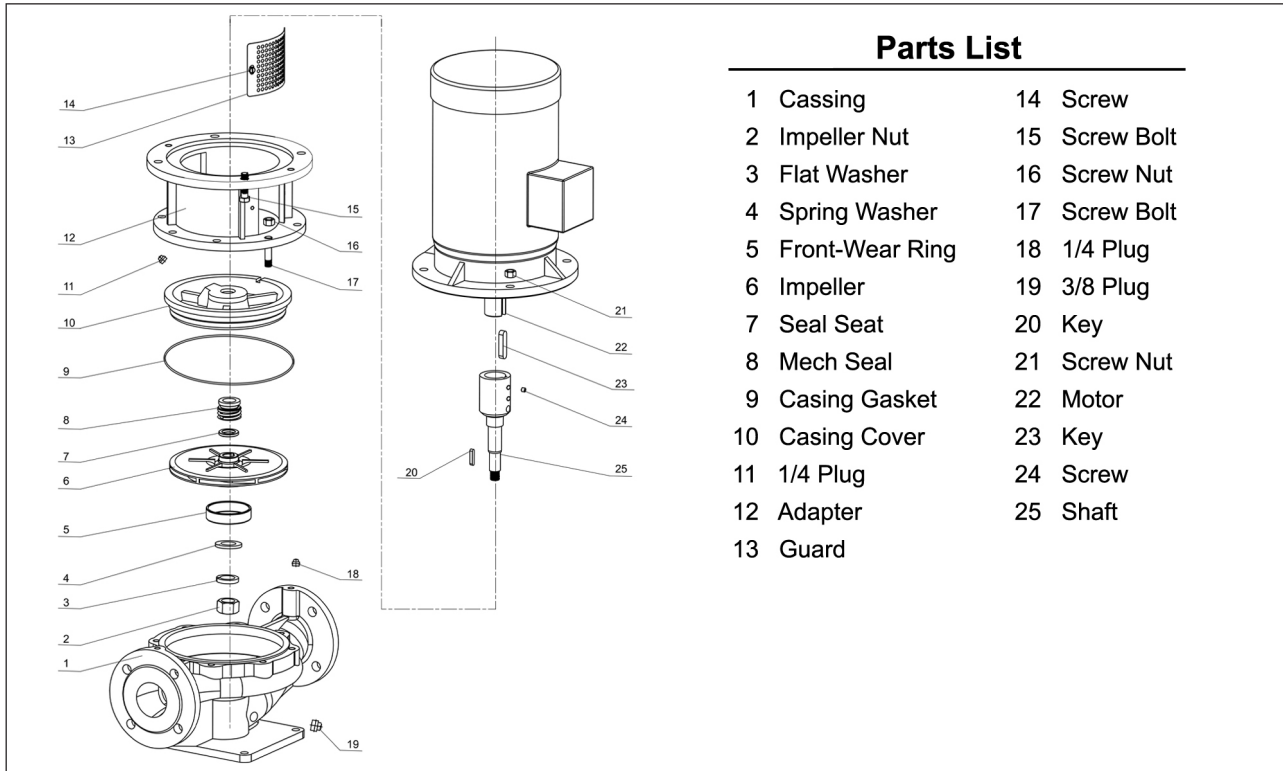

Project

Project ID

Created by

Created on

Last update