



Technical Data

Vertical In-line Pump - EGM65-5032-15004

Revision no.

Page:

1

Receiver

From

 Company name
 Respons. Department
 Person in charge
 Phone number
 Fax no
 E-mail address

--	--



Brand: Gol Pumps
Model: EGM65-5032-15004

Motor (V1)	
Model	HP
Y2-160L-4	20

Weight (lb)		
Pump	Motor	Pump & Motor
226.6	237.6	464.2

Dimensions:

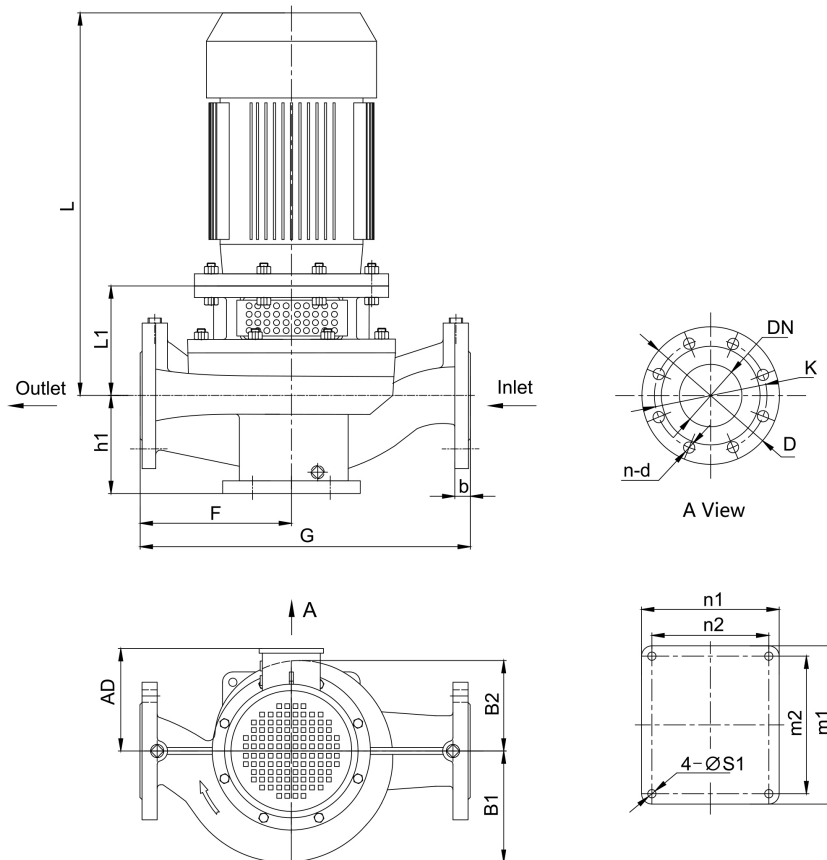

Pump Installation Size (inch)

h1	L1	F	G	L	AD	B1	B2	n2 x m2	n1 x m1	S1	DN	D	K	n - d	b
6.1	9.1	11.4	23.2	31.4	10	8.4	7.8	6.7x7.9	7.9x9.1	0.6	2.5	6.9	5.5	4 - ϕ 0.8	-

Project

Project ID

Created by

Created on

Last update



Performance Curves

Vertical In-line Pump - EGM65-5032-15004

Revision no.

Page:
 2

Receiver

From

Company name
 Respons. Department
 Person in charge
 Phone number
 Fax no
 E-mail address

Model	Capacity			Head		Speed	Motor	Voltage	Phase	Impeller Diam.		Eff.	(NPSH)r
	m ³ /h	l/s	gpm	m	ft	r/min	hp	v		mm	inch	%	ft
EGM65-5032-15004	34.6	9.6	152.2	49	161	1710	20	230/460	3	316	12.4	52	6.2
	57.6	16	253.6	42.5	139		20					57	8.9
	69.1	19.2	304.3	36	118		20					53	11.5

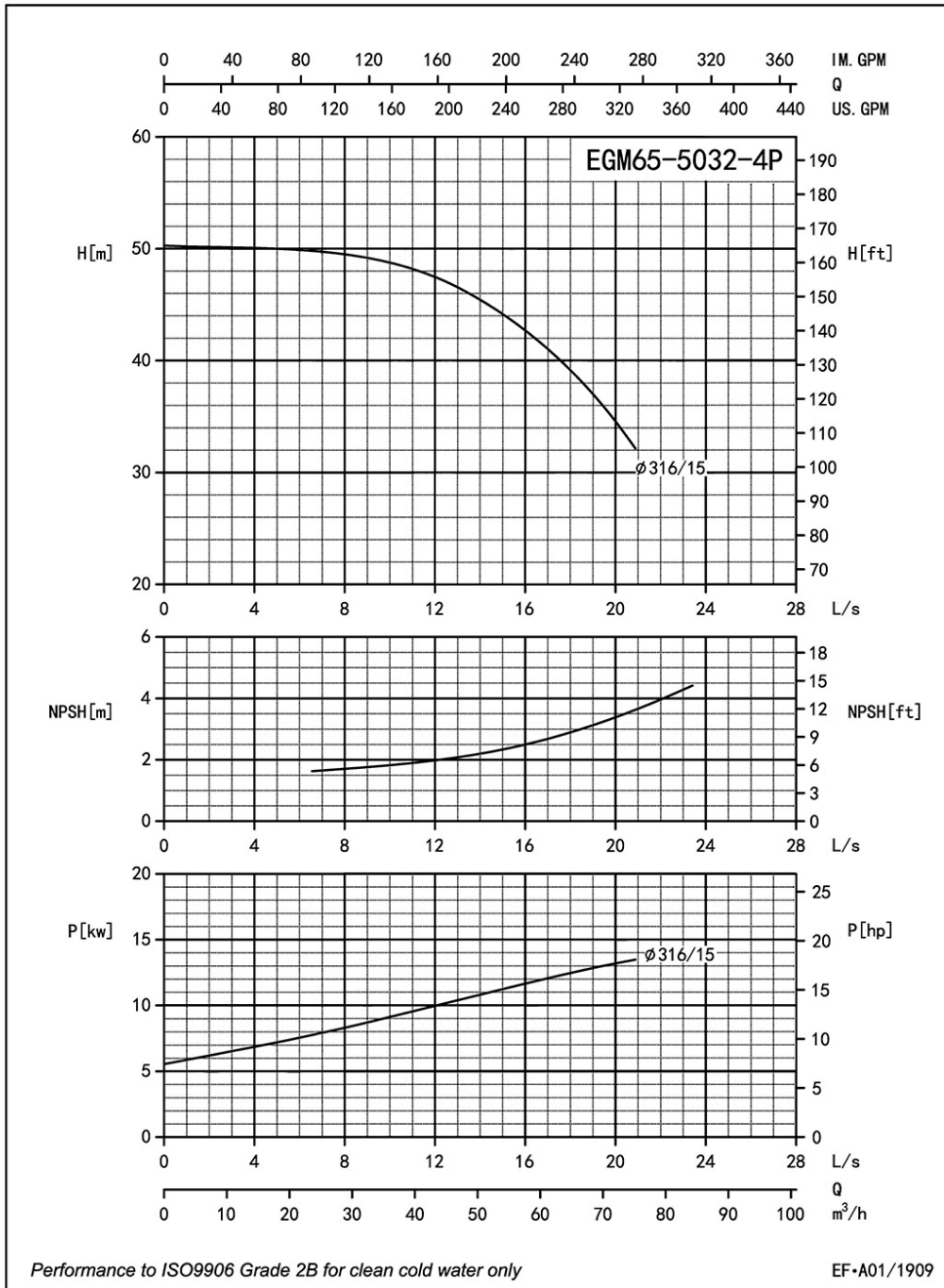

Project	Project ID	Created by	Created on	Last update
---------	------------	------------	------------	-------------



Parts List

Vertical In-line Pump - EGM65-5032-15004

Revision no.

Page:

3

Receiver

From

 Company name
 Respons. Department
 Person in charge
 Phone number
 Fax no
 E-mail address

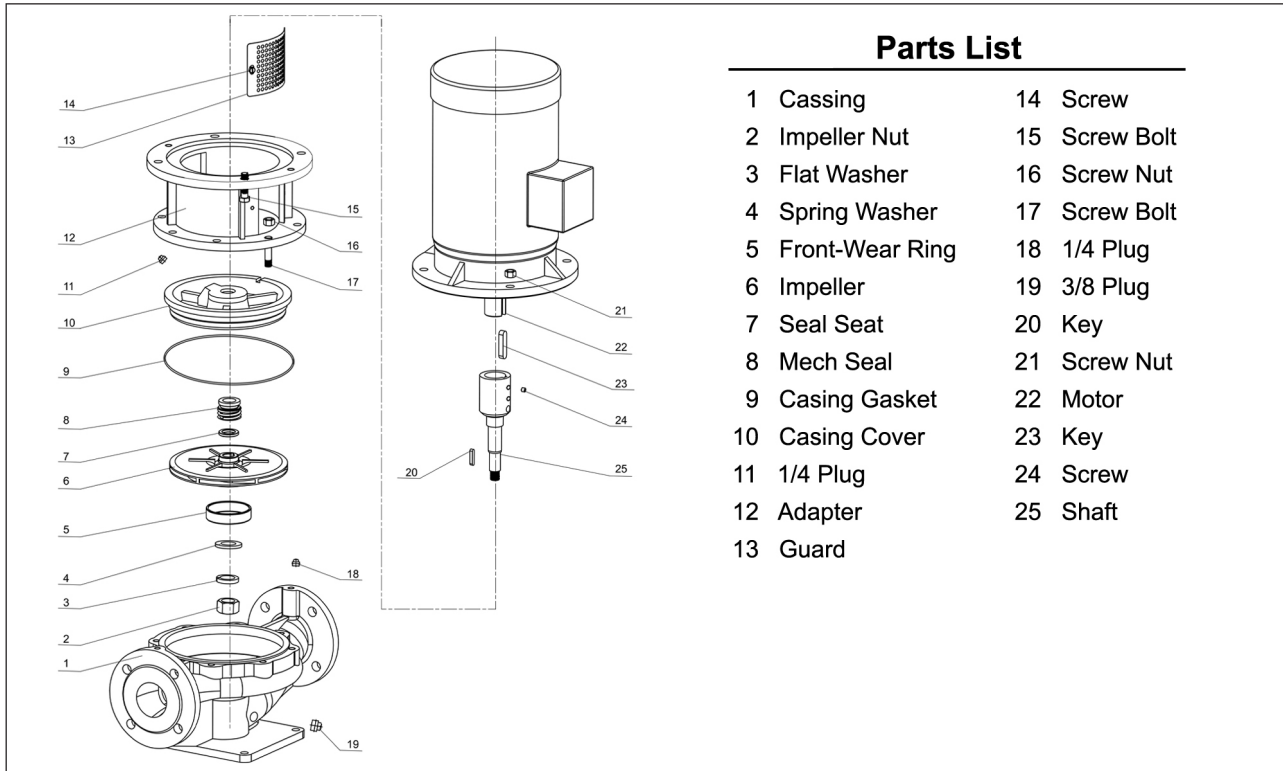

Project

Project ID

Created by

Created on

Last update