

Pump Data

Brand : GOL PUMPS
 Model : G3.5 SD - M 6/3
 Flow Rate: 20 GPM
 Head Rate: 63 FEET
 Head Max: 76 FEET
 Flow Max: 32 GPM
 RPM : 3450 rpm
 Normal Power P2 : 0.5 HP
 Fluid: Water
 Fluid Temperature: at about 25 °C.
 Density: water 1.0 kg/Dm³
 Fluid Viscosity: 8.90 × 10⁻⁴ Pa·s
 With Float switch: NONE
 Kind of Workiny: Submersible
 Delivery size: 1 1/2" NPT
 Suction size: With Strainer
 Made in : CHINA

Motor Data

Power P2: 0.37 KW
 Power P1: *
 Phase (PH): 1
 Rate Voltage : 110 V
 Capacitor Need : 50/250 µF/V
 Ferequency : 60 Hz
 Rated Speed (rpm): 3450 rpm
 Current (A): 7.8 A
 Cos φ : 0.93
 Degree of Protection (IP): IP 68
 Safety Protection Included: F
 length of Cable : 2 M
 Kind of Plug : NONE
 Ambient Temp : 40°C = 104°F

Other Pump Data

Impeller Size (mm) : *
 Pressuer Rating : PN 16
 Min. Fluid Temp : 10°C = 50°F
 Max. Fluid Temp : 35°C = 95°F
 Ambient Temp : 40°C = 104°F
 Humidity % : 100%

Special Specification

Installation status : Vertical
 Variable frequency : NONE
 Solid Passage : 0.25%

Materials

Pump Body : AISI 304 SS
 Support: AISI 304 SS
 Impeller: Plastic POM
 Mechanical Seal: Graphite\Ceramic
 Rubber: NBR
 Pump Shaft: AISI 304 SS
 Strainer: AISI 304 SS
 outer cover: Cast Iron
 Motor Case: AISI 304 SS

Shaft Seal

Type: *
 Stationary Part: Ceramic
 Rotating Part: Graphite
 Elastomer: NBR

Pump and Motor specification optional

With Booster System: None
 With Complack: None
 Special Material: None
 Specail Voltage: None

Protection system required

External Flout switch: NONE
 Minimum Starter: Over Load and Capacitor Box Include

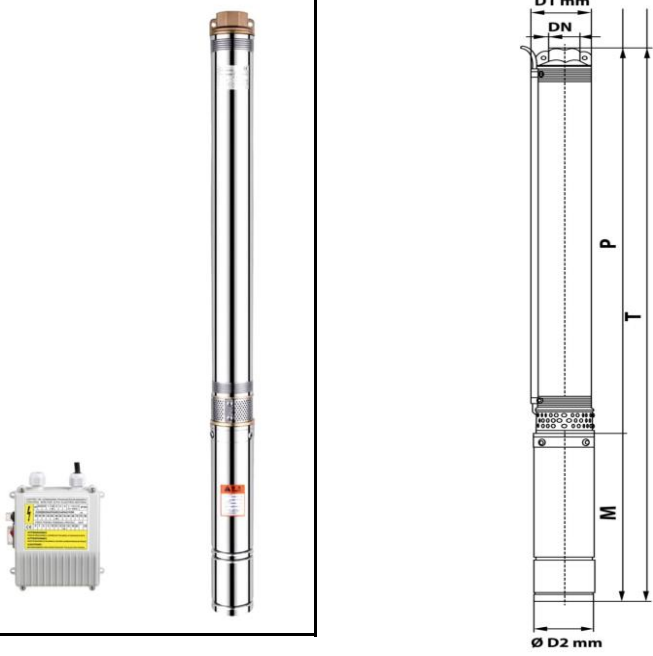
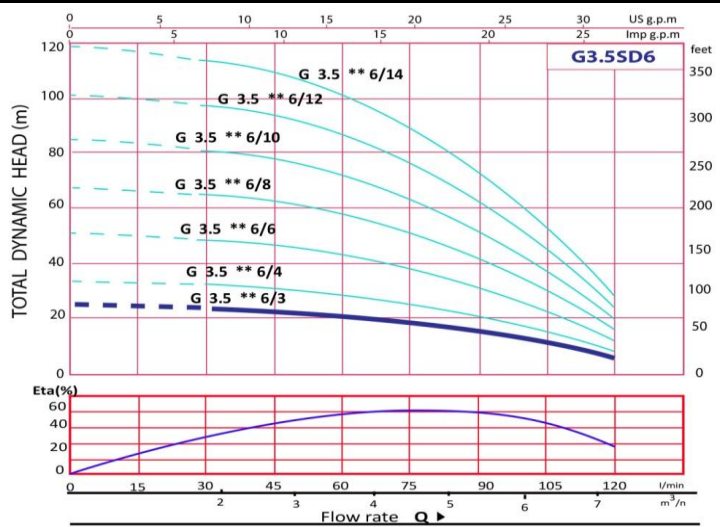

Weight : 7.7 Kg	Applicant:	Dimention in	
Standard Approve	For Water Supply from Wells or Reservoirs for Domestic Use for Civil and Industrial Applications for Garden Use and Irrigation	mm	
CE		P	296
		M	318
		T	614
		DN	1 1/2"
		D1	85
		D2	84