



GOL PUMPS CO.

SOLAR OFF-GRID POWER SYSTEM

System Introduction

The system is composed of solar panels, Solar Off-grid Inverter, MPPT charge controller and battery pack. Solar off-grid inverter is the core device of solar power system, it converts DC power produced by solar panels to AC power to provide electric energy for appliances. MPPT charge controller charges the solar electricity into batteries. When solar energy is not enough for the loads, or at night, the battery pack will discharge to replenish energy for loads.



System Features

Safety

- Overload and short circuit protection;
- Auto restart while AC is recovering;
- Compatible to mains voltage or generator power;

Smart

- Perfect pure sine wave output;
- Selectable charging current;
- Configurable AC/ DC input priority via LCD setting;

Reliable

- Built-in pure copper transformer;
- Silicon-controlled rectifier(SCR) be adopted in AC by-pass;
- Provide power supply to load for 24 hours;

Intelligent

- Advanced battery management system (BMS);
- Support sealed battery and lithium battery;
- Special AC output design, adopt emergency & heavy loads separate control.

Solar Off-Grid Inverter with Hybrid Controller, Single Phase 1kVA-5kVA



Product Features

- 01 FEATURE** AC input source compatible with AC grids and diesel generator, and intelligent control;
- 02 FEATURE** Built-in MPPT solar charge controller;
- 03 FEATURE** Smart battery charger Design for optimized battery performance;
- 04 FEATURE** Intelligent charge Management and AC output management system;
- 05 FEATURE** Overload and short-circuit protection;
- 06 FEATURE** Two 115V output and One 230V output~ at same time online;
- 07 FEATURE** Output frequency is 60Hz.

Introduction:

Combing functions of inverter, AC charger, solar MPPT charge controller, and AC by-pass to offer uninterrupted power support with portable size. The comprehensive LCD display offers user-configurable and easy accessible button operation. It supports mains/ generator input, special design for AC output 115V and 230V on-line at the same time. The inverter is with output of 1kVA~5kVA, supplying power for the places without city power e.g. remote areas, pastoral areas, islands, communication base stations, etc.

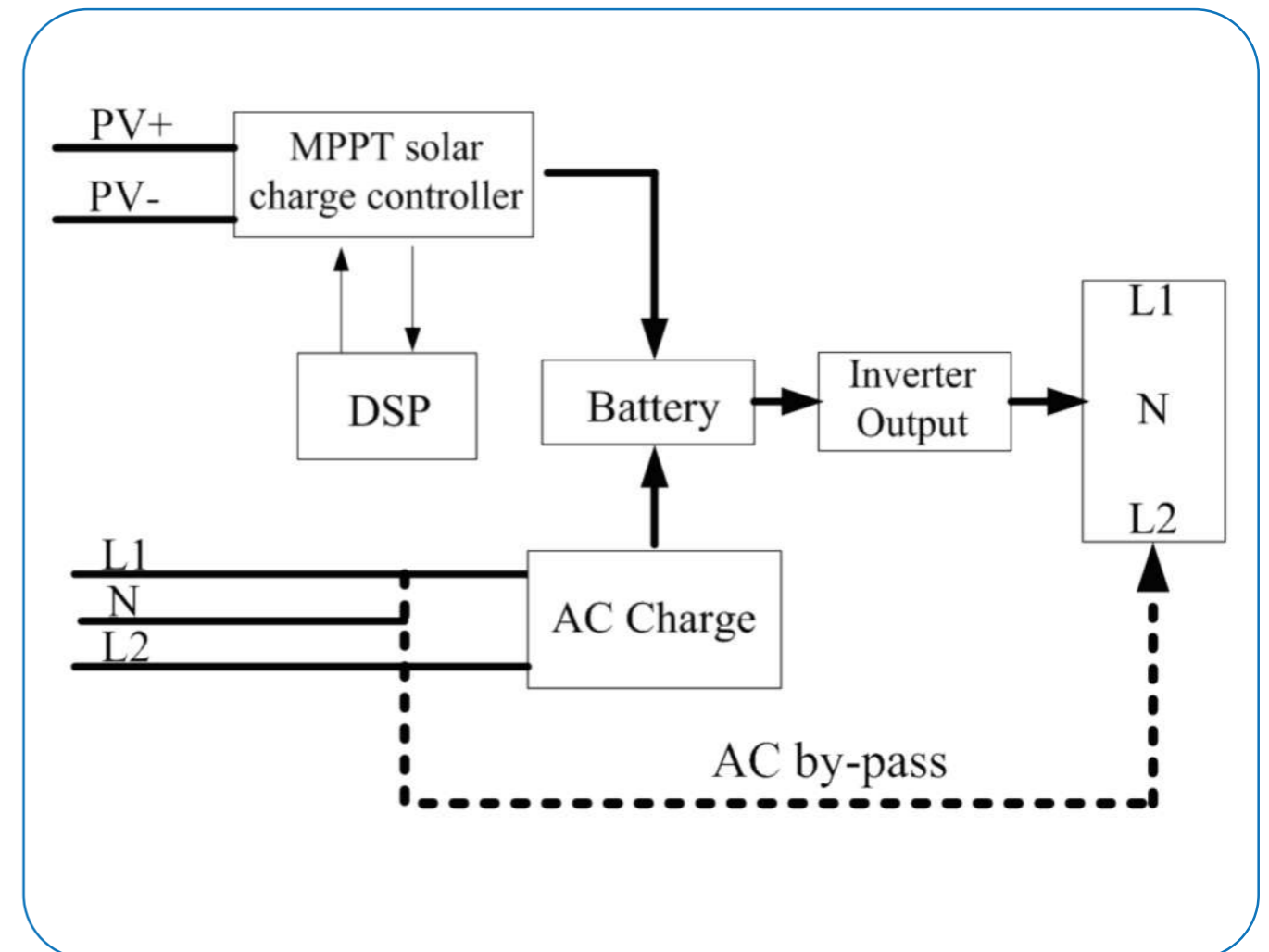
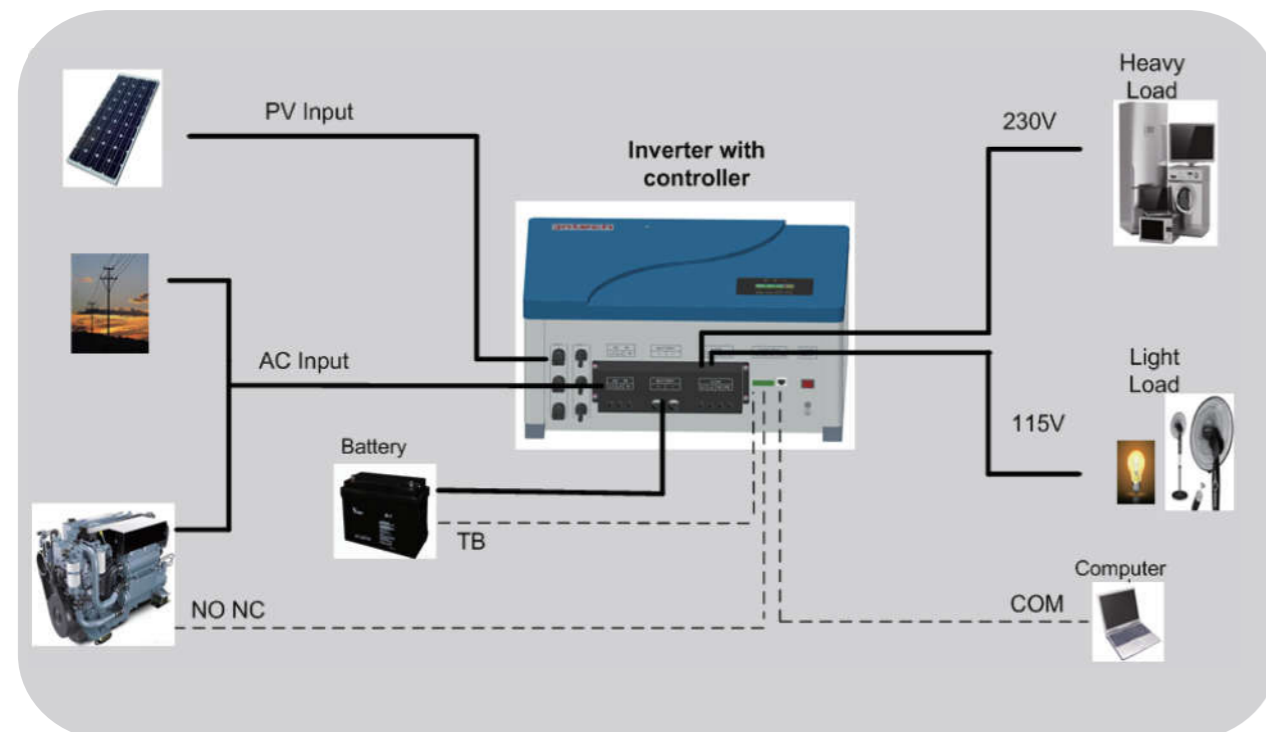

Wiring diagram

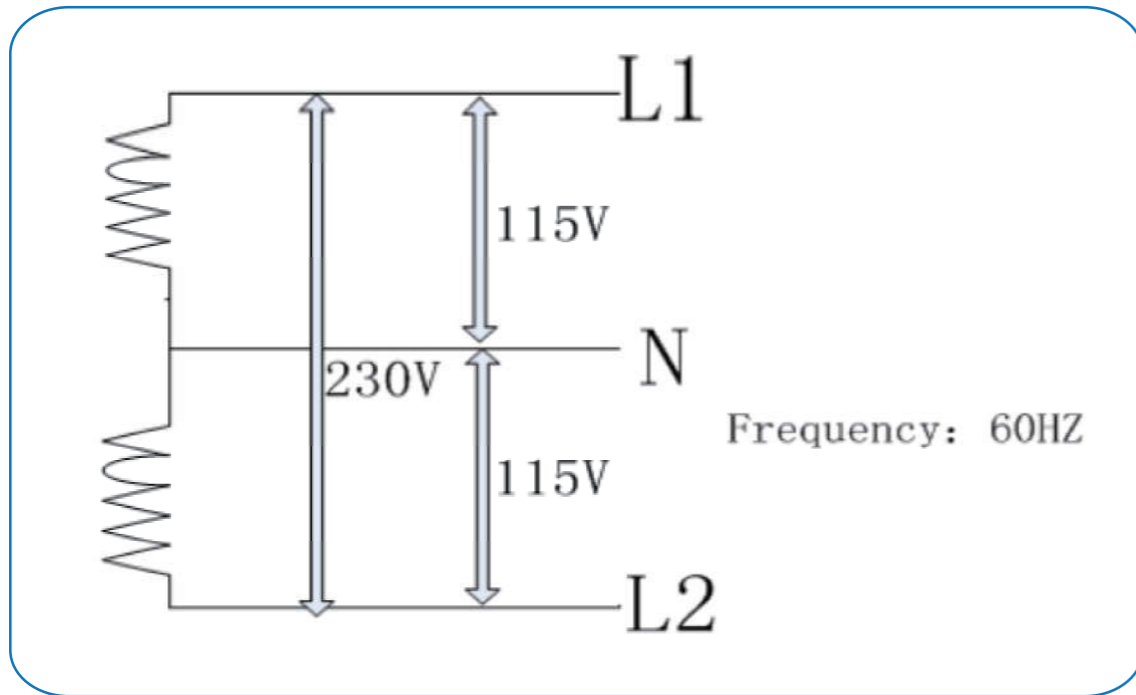

System topology

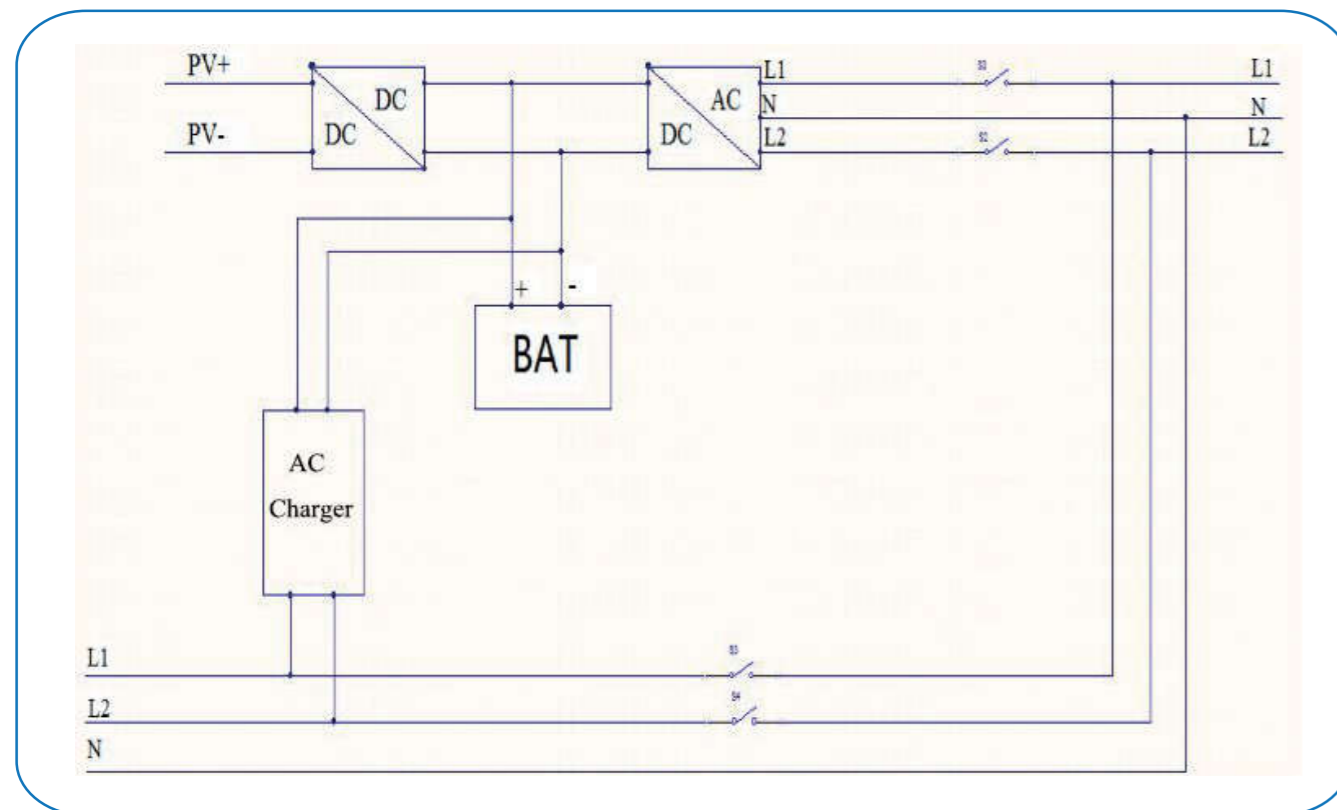

GOL PUMPS CO.

3750 NW 114 Ave #6 , Miami - Florida - 33178

info@golpumps.com

+1 (786) 615-8984, +1 (786) 615-7043

Model	JNF1KLF/24V-G20A	JNF1K5LF/24V-G20A	JNF2KLF/24V-G20A	JNF3KLF/48V-G20A	JNF4KLF/48V-G20A	JNF5KLF/48V-G20A
PV Input						
Max. PV array input voltage	150Vdc	150Vdc	150Vdc	150Vdc	150Vdc	150Vdc
MPPT voltage range	35~145Vdc	35~145Vdc	35~145Vdc	65-145Vdc	65-145Vdc	65-145Vdc
Battery						
Rated voltage	24Vdc	24Vdc	24Vdc	48Vdc	48Vdc	48Vdc
Max. charge current	40A	40A	40A	40A	40A	60A
Efficiency	≥96%	≥96%	≥96%	≥97%	≥97%	≥97%
Inverter Output						
Rated output capacitor	500VA(L-N)/1000VA(L-L)	750VA(L-N)/1500VA(L-L)	1000VA(L-N)/2000VA(L-L)	1500VA(L-N)/3000VA(L-L)	2000VA(L-N)/4000VA(L-L)	2500VA(L-N)/5000VA(L-L)
Rated output power	400W(L-N)/800W(L-L)	600W(L-N)/1200W(L-L)	800W(L-N)/1600W(L-L)	1200W(L-N)/2400W(L-L)	1600W(L-N)/3200W(L-L)	2000W(L-N)/4000W(L-L)
Output voltage	115Vac(L-N)/230Vac(L-L)					
Rated frequency	60Hz (±3%)					
Max. efficiency	≥90%	≥90%	≥90%	≥90%	≥90%	≥90%
Total harmonic distortion (THD)	<3%					
Rated current	4.5A	7A	9A	13.5A	18A	22.5A
Current peak factor	3:1					
Overload	125%@rated power,70S;150%@rated power,20S; 200%@rated power,5S; 300%@rated power,0S;					
AC Input						
AC input voltage	230Vac (±15%)					
AC input frequency	60Hz (±3%)					
Max. charge current	20A					
Grid pass-by						
Allowed input voltage	115Vac±10%/230Vac±20%					
Switching time	<100ms					
Mechanical data						
Dimension(W*D*H)(mm)	485*365*235					500*365*235
Weight	17kg	18kg	27kg	28kg	30kg	35kg
Other						
Protection level	IP22					
Autible noise	<50dB					
Cooling method	Forced cooling					
Operate temp.	-20 ~ +50°C					
Storage temp.	-25 ~ +70°C					
Status indicator	LCD+LED					
Interface	RS485					
Elevation	2000m(2000m derating operate)					