



Technical Data

Vertical In-line Pump - EGM65-4026-02204

Revision no.

Page:

1

Receiver

From

 Company name
 Respons. Department
 Person in charge
 Phone number
 Fax no
 E-mail address

Brand: Gol Pumps
Model: EGM65-4026-02204
Flange: ANSI Class 125

Motor (V1)

Model	HP
Y2-100L1-4	3

Weight (lb)

Pump	Motor	Pump & Motor
145.2	74.8	220

Inlet Outlet

2.5"	2.5"
------	------

Dimensions:

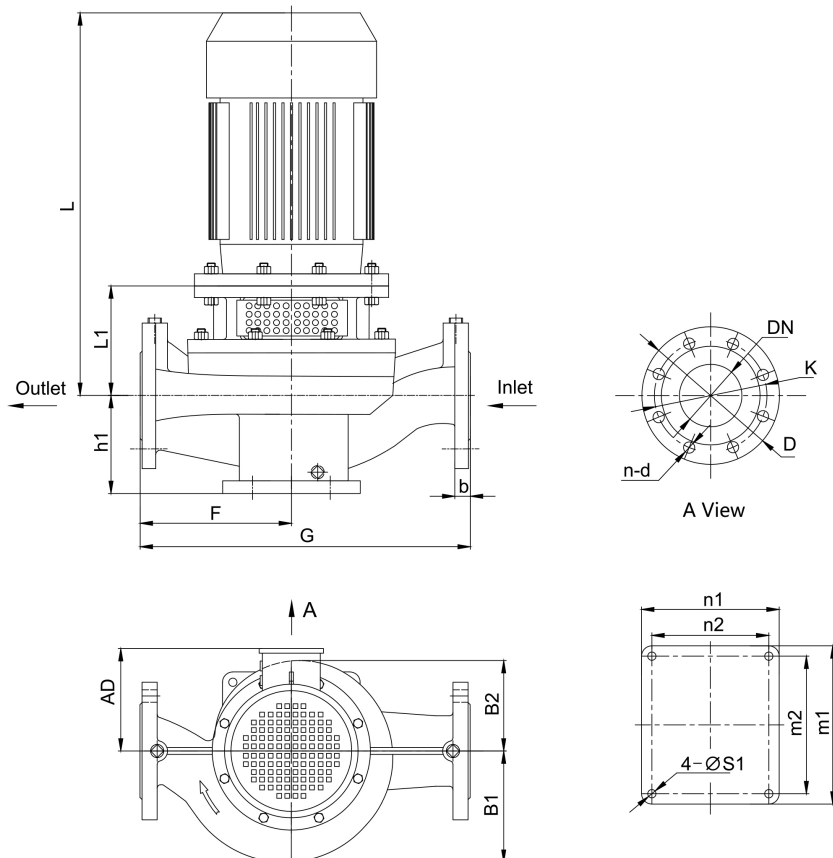

Pump Installation Size (inch)

h1	L1	F	G	L	AD	B1	B2	n2 x m2	n1 x m1	S1	DN	D	K	n - d	b
5.4	6.8	10.2	20.5	19.6	7.1	6.6	6.6	6.7x7.9	7.9x9.1	0.6	2.5	7.1	5.5	4 - φ0.8	-

Project

Project ID

Created by

Created on

Last update



Performance Curves

Vertical In-line Pump - EGM65-4026-02204

Revision no. _____

Page:
 2

Receiver	From

Company name
 Respons. Department
 Person in charge
 Phone number
 Fax no
 E-mail address

Model	Capacity			Head		Speed r/min	Motor hp	Voltage v	Phase	Impeller Diam.		Eff. %	(NPSH) r ft
	m ³ /h	l/s	gpm	m	ft					mm	inch		
EGM65-4026-02204	12.2	3.4	53.3	17.7	58	1710	3	230/460	3	205	8.1	38	6.6
	20.2	5.6	88.8	15.7	52		3					48	8.2
	24.1	6.7	106.5	13	43		3					42	11.5

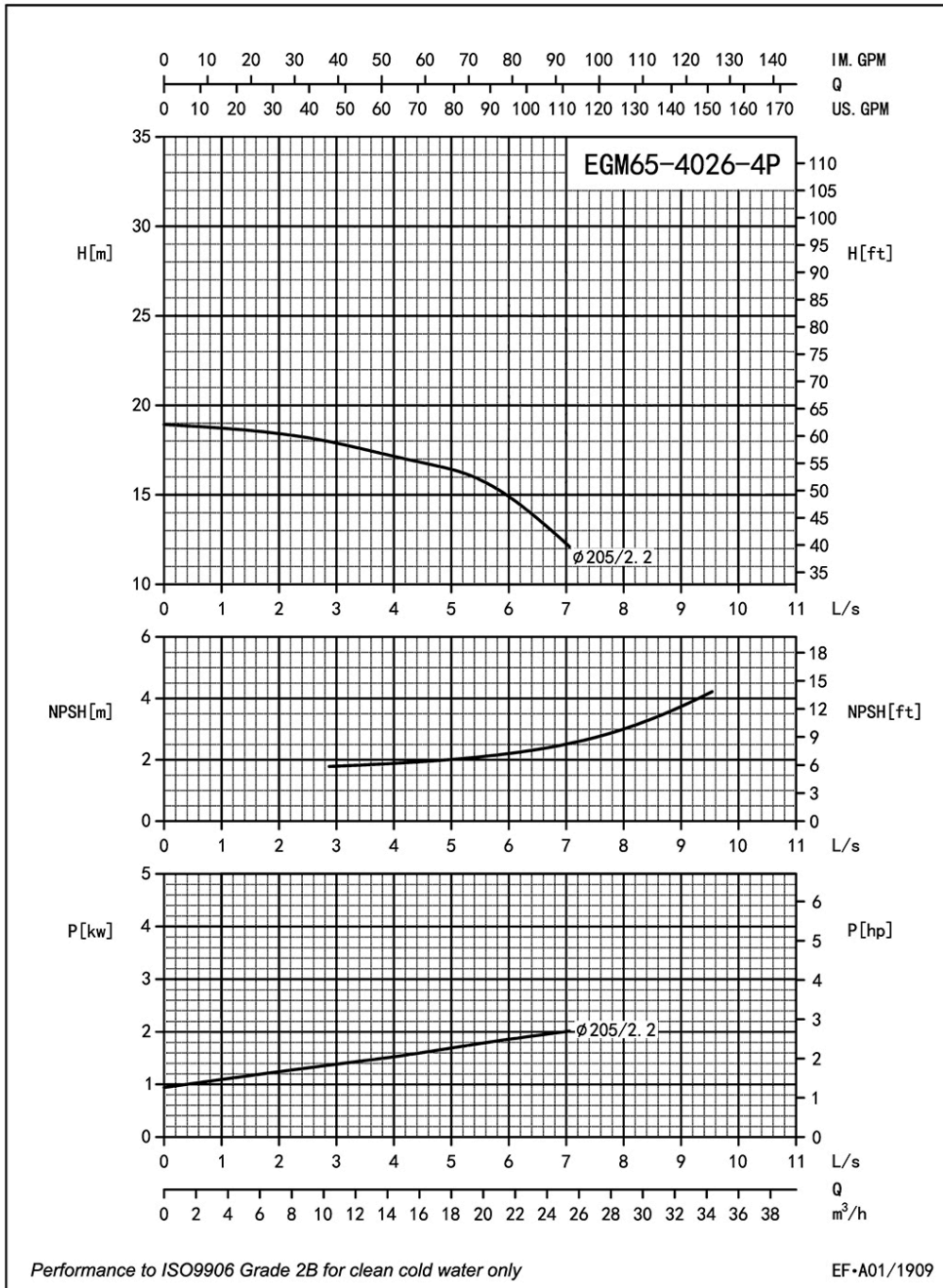

Project	Project ID	Created by	Created on	Last update
---------	------------	------------	------------	-------------



Parts List

Vertical In-line Pump - EGM65-4026-02204

Revision no.

Page:
 3

	Receiver	From
Company name		
Respons. Department		
Person in charge		
Phone number		
Fax no		
E-mail address		

Parts List

1 Cassing	14 Screw
2 Impeller Nut	15 Screw Bolt
3 Flat Washer	16 Screw Nut
4 Spring Washer	17 Screw Bolt
5 Front-Wear Ring	18 1/4 Plug
6 Impeller	19 3/8 Plug
7 Seal Seat	20 Key
8 Mech Seal	21 Screw Nut
9 Casing Gasket	22 Motor
10 Casing Cover	23 Key
11 1/4 Plug	24 Screw
12 Adapter	25 Shaft
13 Guard	

Project	Project ID	Created by	Created on	Last update