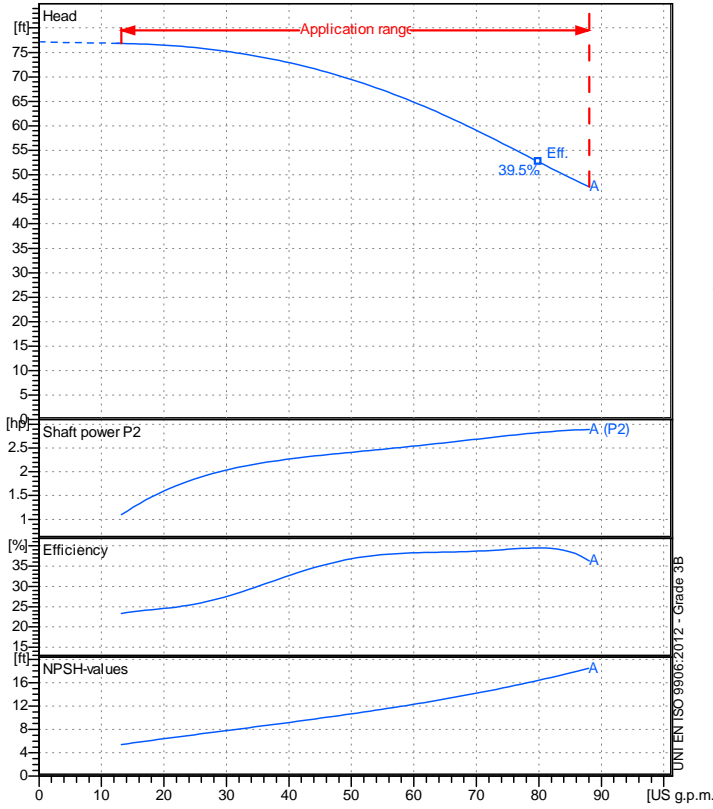

Receiver

From

 Company name
 Respons. Department
 Person in charge
 Phone number
 Fax no
 E-mail address

Operating data specification

Nominal flow	US g.p.m.	0
Nominal head	ft	0
Static head	ft	0
NPSH - v value of plant	ft	0
Inlet pressure	psi	1.42
Fluid		Water, pure
Operating temperature t A	°F	68
Density at t A	lb/ft³	62.32
Kin. viscosity at t A	ft²/s	1.082E-5

Pump

Pump name	JNCB 32-200NA		
Size	50/32/200		
Design			
Speed rpm	1800	No of stages	1
Impeller type			
Flow	Nominal	US g.p.m.	
	Max-	US g.p.m.	88.1
	Min-	US g.p.m.	13.2
Head	Nominal	ft	
	Max-	ft	76.8
	Min-	ft	47.5
Head H(Q=0)	ft	77.2	
NPSH 3%	ft		
Max. working pressure	psi	33.4	
Shaft power	hp		
Efficiency	%		
Max absorbed power	hp	2.8881	

Materials Pump

Shaft	Stainless steel AISI 431 (1.4057)
Impeller	Cast iron EN-GJL-250
Pump body	Cast iron EN-GJL-250
Seal disc	Cast iron EN-GJL-250
Gasket	Natural fiber

Mech. seal EN 12756

Seal face	Carbon graphite resin impreg.
Seat	Alumina Oxide
Rubber elements	EPDM Rubber
Spring and metal bellows	Stainless steel AISI 316

Motor	Frame size		
Manufacturer / Type			
Rated power	hp	Efficiency	4/4
Electric current	A	Speed	rpm
Electric voltage	V		Hz
Starting mode			
Degree of protection		Insulation class	

Remarks:

Dimensions in inch

A	3/8"	n2	7 1/2
a	3 1/8	s	9 1/16
B	3/8"	t	1 1/16
b	1 5/16	u	5 1/16
C	1/4"	w	10 1/4
d k6	1 5/16	x	3 15/16
D	1/4"		

DNA DN 50

DNM DN 32

f 14 3/16

h1 6 5/16

h2 7 1/16

l 1 5/16

m1 3 15/16

m2 2 3/4

n1 9 7/16

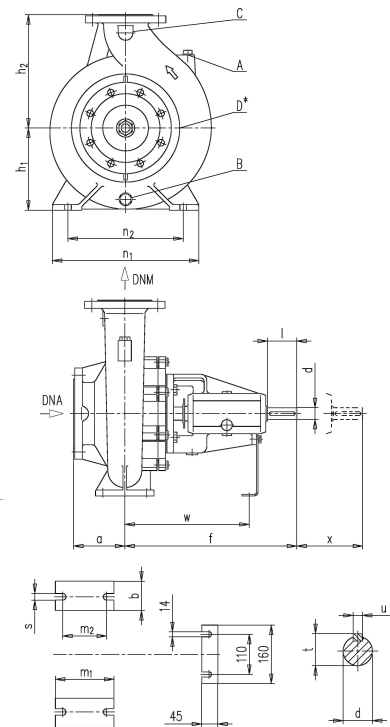

Project	Project ID	Created by	Created on	Last update
			2022-10-19	



Performance Curves JNCB 32-200NA

Revision no

Page:
2

Receiver

From

Company name
Respons. Department
Person in charge
Phone number
Fax no
E-mail address

Operating area	Flow	Head	Impeller type
Operating data specification	0 US g.p.m.	0 ft	Impeller construction: Closed
Pump data	US g.p.m.	ft	Sense of rotation: Clockwise from the drive end
			Outlet width: DN 32
	Flow	Head	Shaft power P2
	Min. Max. η Max.	H(Q=0) η Max.	P2(Q=0) Max. η Max.
	US g.p.m. US g.p.m. US g.p.m.	ft ft	hp hp hp
	13.2 88.1 79.9	77.2 52.6	2.89 2.82
			Speed rpm: 1800
			Frequency Hz

Performance data based to: Water, pure [100%]; 68°F; 62.3lb/ft³; 1.08E-5ft²/s

UNI EN ISO 9906:2012 - Grade 3B

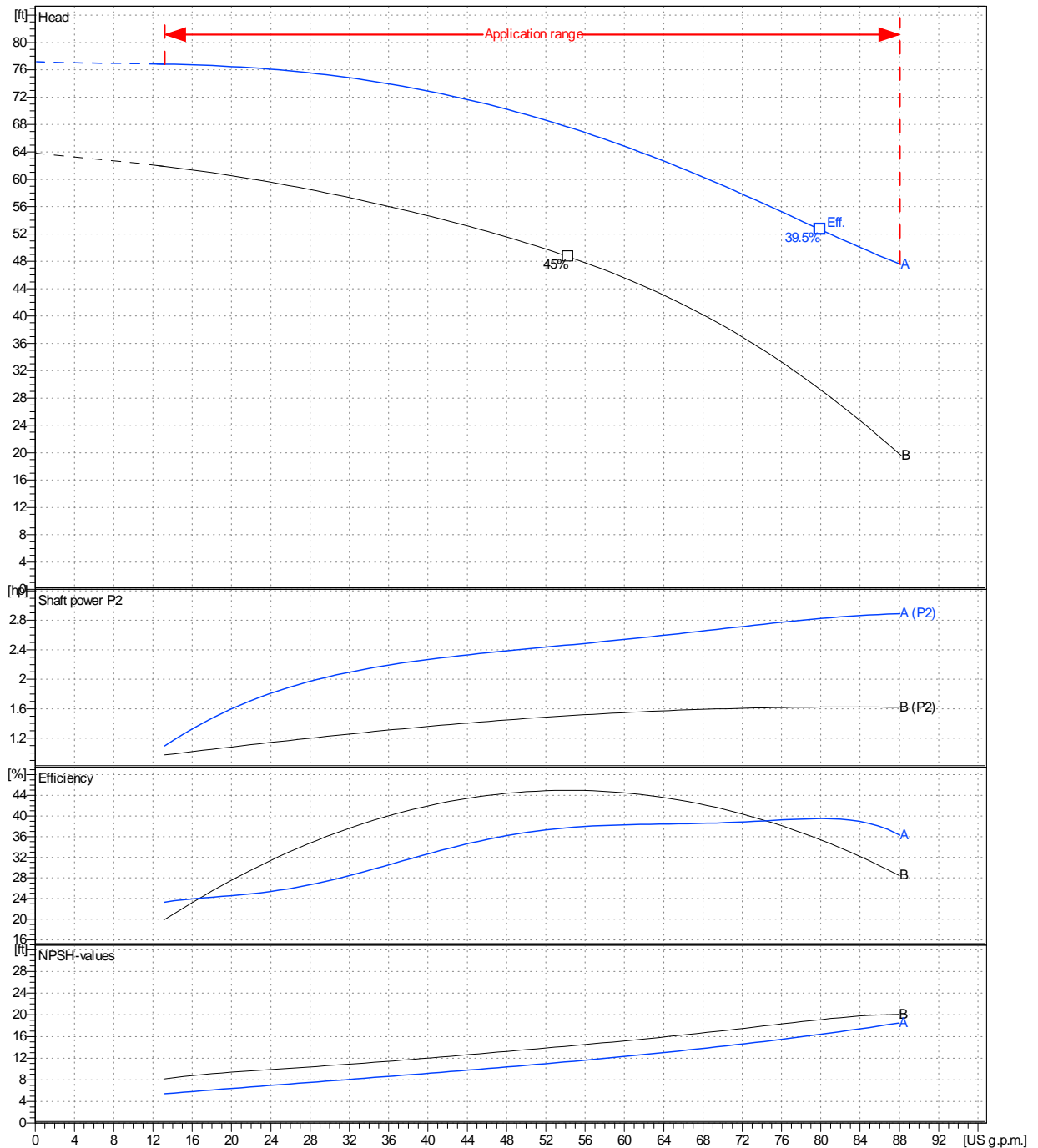

Project	Project ID	Created by	Created on 2022-10-19	Last update
---------	------------	------------	--------------------------	-------------

Receiver

From

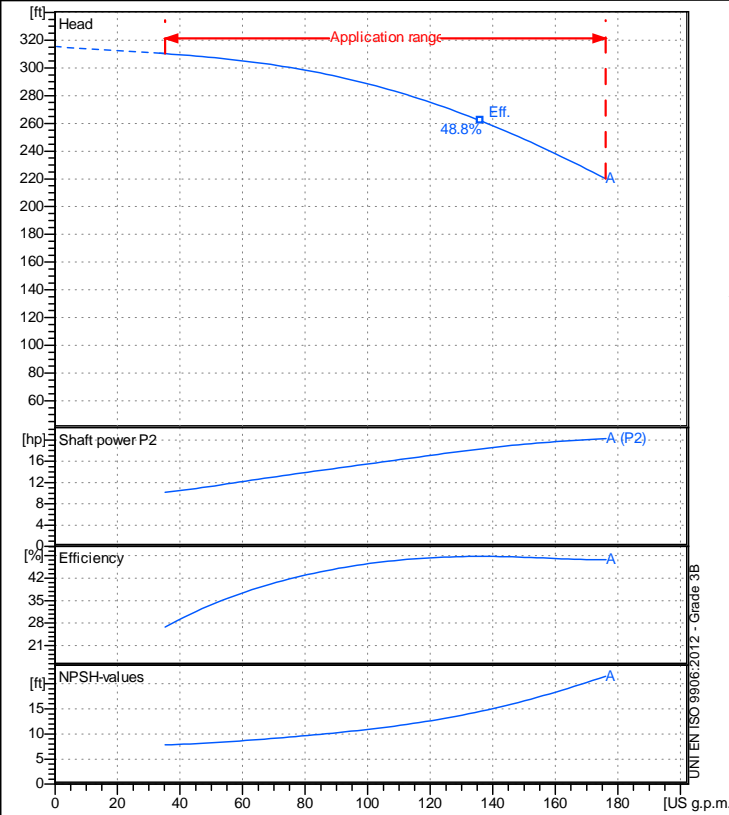
 Company name
 Respons. Department
 Person in charge
 Phone number
 Fax no
 E-mail address

Operating data specification

Nominal flow	US g.p.m.	0
Nominal head	ft	0
Static head	ft	0
NPSH - v value of plant	ft	0
Inlet pressure	psi	1.42
Fluid	Water, pure	
Operating temperature t A	°F	68
Density at t A	lb/ft ³	62.32
Kin. viscosity at t A	ft ² /s	1.082E-5

Pump

Pump name	JNCB 32-200NA		
Size	50/32/200		
Design			
Speed rpm	3600	No of stages	1
Impeller type			
Flow	Nominal	US g.p.m.	
	Max-	US g.p.m.	176
	Min-	US g.p.m.	35.2
Head	Nominal	ft	
	Max-	ft	310
	Min-	ft	220
Head H(Q=0)	ft	315	
NPSH 3%	ft		
Max. working pressure	psi	137	
Shaft power	hp		
Efficiency	%		
Max absorbed power	hp	20.28	

Materials Pump

Shaft	Stainless steel AISI 431 (1.4057)
Impeller	Cast iron EN-GJL-250
Pump body	Cast iron EN-GJL-250
Seal disc	Cast iron EN-GJL-250
Gasket	Natural fiber

Mech. seal EN 12756

Seal face	Carbon graphite resin impreg.
Seat	Alumina Oxide
Rubber elements	EPDM Rubber
Spring and metal bellows	Stainless steel AISI 316

Motor	Frame size	
Manufacturer / Type		
Rated power	hp	Efficiency 4/4
Electric current	A	Speed rpm
Electric voltage	V	Hz
Starting mode		
Degree of protection		Insulation class

Remarks:

Dimensions in inch

A	3/8"	n2	7 1/2
a	3 1/8	s	9 1/16
B	3/8"	t	1 1/16
b	1 15/16	u	5 1/16
C	1/4"	w	10 1/4
d k6	15/16	x	3 15/16
D	1/4"		
DNA	DN 50		
DNM	DN 32		
f	14 3/16		
h1	6 5/16		
h2	7 1/16		
l	1 15/16		
m1	3 15/16		
m2	2 3/4		
n1	9 7/16		

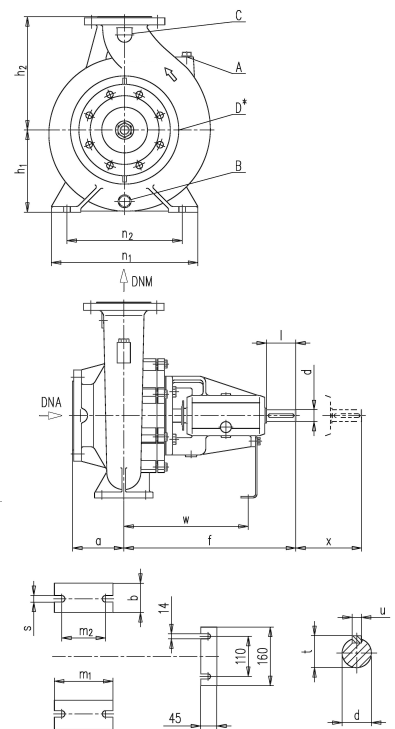

C	3 1/16	C	4
D	5 1/2	D	6 1/2
DN	1 1/4	DN	1 15/16
K	3 15/16	K	4 15/16
n°	3/16	n°	3/16
ø n	3/4	ø n	3/4

Project

Project ID

Created by

 Created on
2022-10-19

Last update



Performance Curves JNCB 32-200NA

Revision no

Page:

4

Receiver

From

Company name
Respons. Department
Person in charge
Phone number
Fax no
E-mail address

Operating area	Flow	Head	Impeller type
Operating data specification	0 US g.p.m.	0 ft	Impeller construction Closed
Pump data	US g.p.m.	ft	Sense of rotation Clockwise from the drive end
	Min. Max. η Max.	H(Q=0) η Max.	Outlet width DN 32
	US g.p.m. US g.p.m. US g.p.m.	ft ft	Speed rpm 3600
		P2(Q=0) Max. η Max.	Frequency Hz
	35.2 176 136	315 262	
		hp hp hp	
		20.3 18.3	

Performance data based to: Water, pure [100%]; 68°F; 62.3lb/ft³; 1.08E-5ft²/s

UNI EN ISO 9906:2012 - Grade 3B

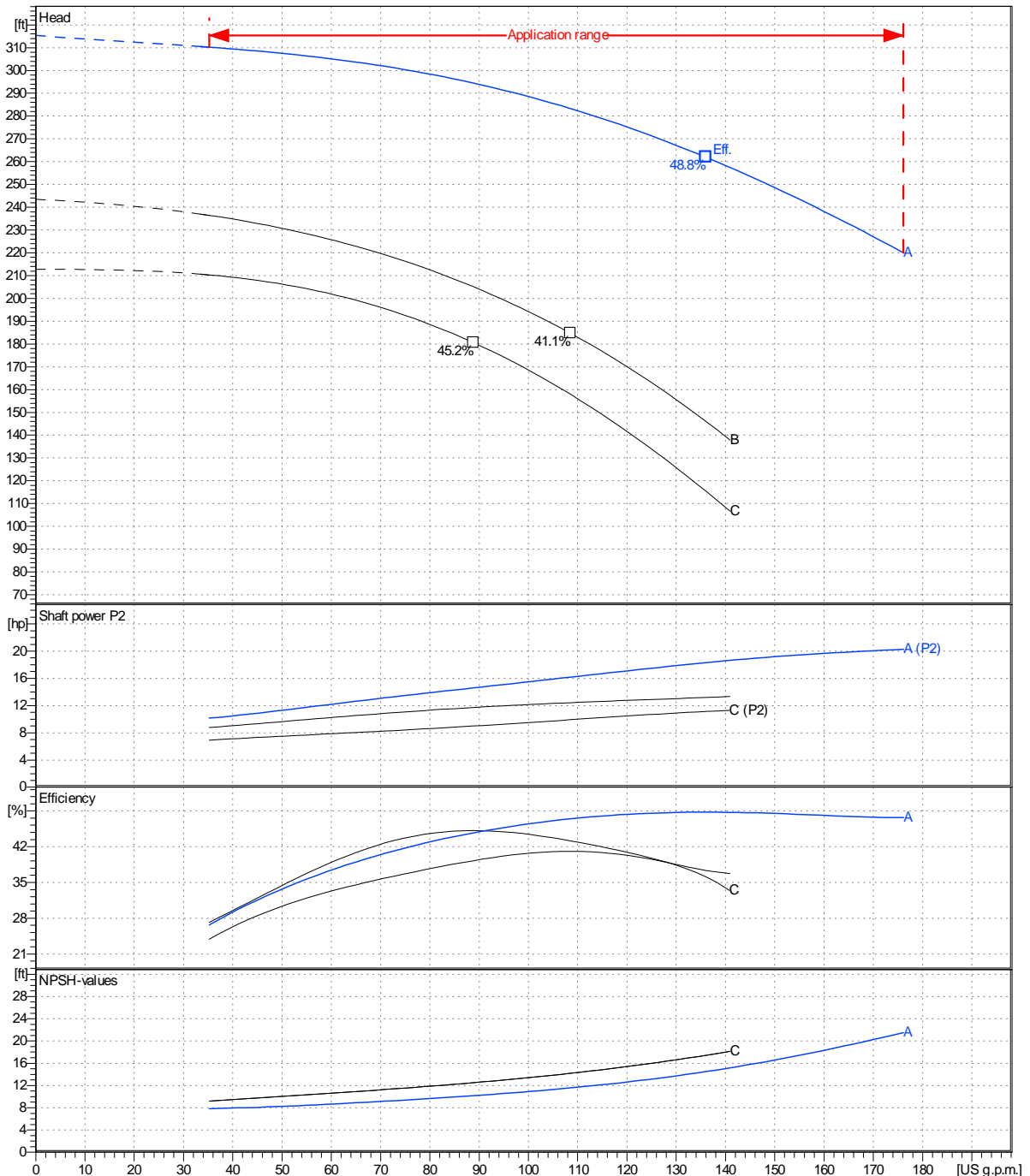

Project

Project ID

Created by

Created on
2022-10-19

Last update

Company name
Respons. Department
Person in charge
Phone number
Fax no
E-mail address

