



RECYCLED PAPER

CARING FOR THE FUTURE

CATALOG
USA 60Hz



FEKA 40th

SUBMERSIBLE PUMPS FOR EFFLUENT



FEKA M-A

FEKAM-NA



Flow rate minimum and maximum
from 4.4 to 70.4 GPM

Head up to 25 ft

Type of pumped liquid wastewater and rainwater

Free passage 1 in

Supported liquid temperature (maximum and minimum) from 32°F to +95°F for domestic use

Class of protection IP 68

Motor insulation class F

Possible type of installation
fixed or portable in vertical position

Submersible pumps suitable for draining and lifting effluent wastewater and rainwater in residential building service. The pumps have been redesigned on the occasion of the forty year anniversary, making them even more reliable, resistant and ergonomic.

The impeller in technopolymer allows the passage of solid bodies up to 1in. The pumps are designed for fixed or mobile installations and are available in automatic versions with integrated float switch or in manual version without float.

The pump body and the inlet grid are in technopolymer, the motor shaft in AISI 431 motor shaft suitable for light salty water.

Robust and reliable, they have a triple ring seal in oil bath and an asynchronous motor with continuous service. Stator inserted in an airtight stainless steel casing and rotor mounted on oversized ball bearings to increase its durability.

Thermal protection incorporated in all single-phase versions. the pumps can run dry for up to 1 minute. New sealed cable gland design and new motors, more compact and efficient. Impeller bolt sealing to prevent corrosion at bolt motor shaft. In compliance with CSA Standards C22.2 No.108 - 14, UL Standard No. 778.

ACCESSORIES
PAG. 159

TECHNICAL DATA

MODEL	CODE	ELECTRICAL DATA						
		VOLTAGE 60 Hz	P1 MAX kW	P2 NOMINAL		In A	CAPACITOR	
				kW	HP		μF	Vc
FEKA 300 MA	60198427H	115-120	0.4	0.2	0.3	4.0	20	250
FEKA 300 MNA	60200871H	115-120	0.4	0.2	0.3	4.0	20	250
FEKA 600 MA	60198424H	115-120	0.7	0.5	0.6	6.3	20	250
FEKA 600 MNA	60200872H	115-120	0.7	0.5	0.6	6.3	20	250

RANGE PERFORMANCE

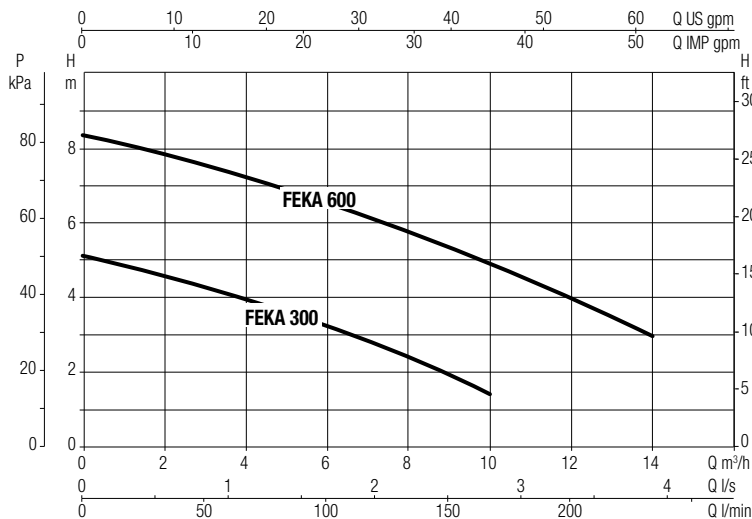

FEKA 40th

SUBMERSIBLE PUMPS FOR EFFLUENT

DIMENSIONS AND WEIGHT

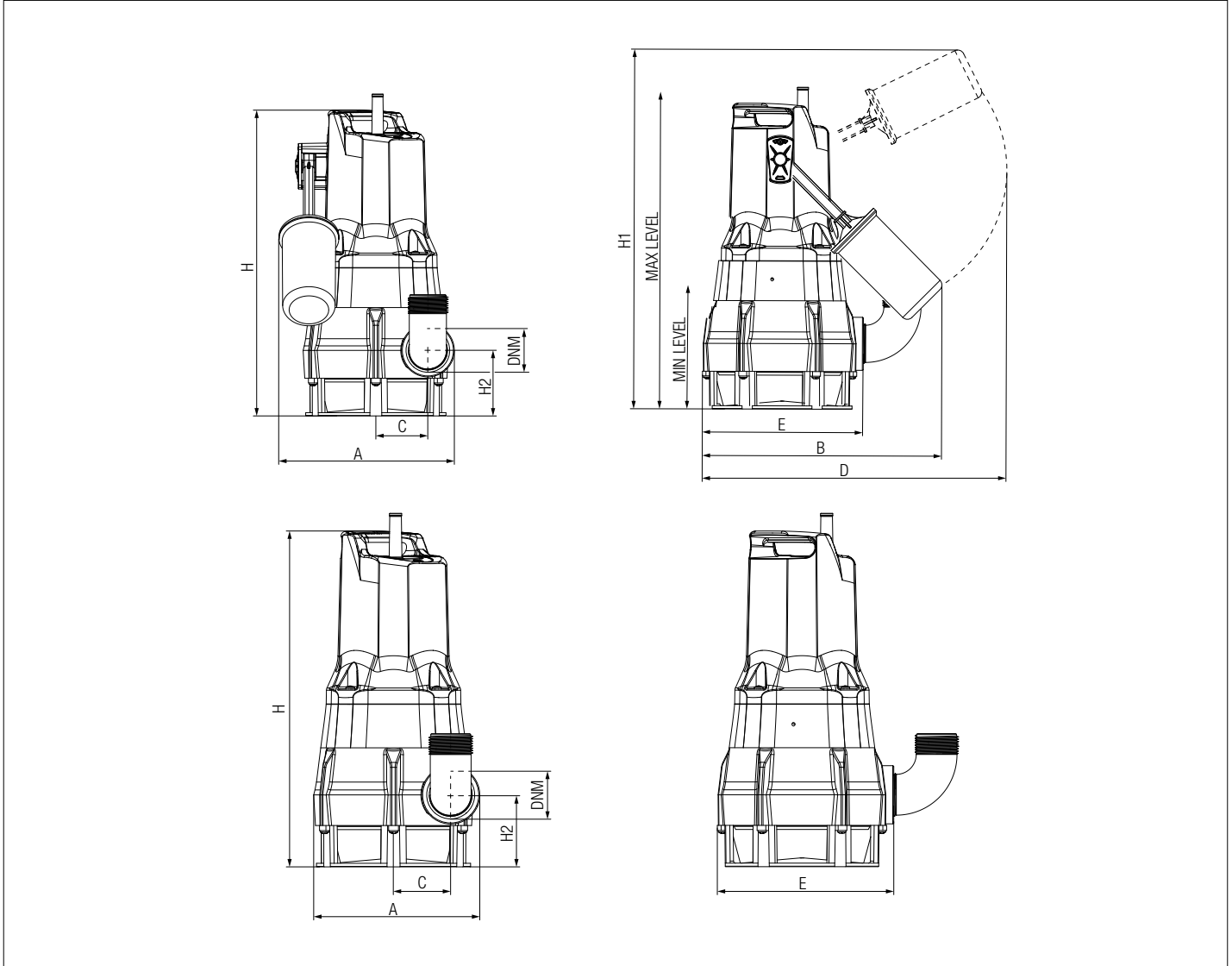

MODEL	A	B	C	D	E	H	H1	H2	LEV. MIN	DNM NPT	PACKING DIMENSIONS			CABLE LENGHT (ft)	VOLUME (ft ³)	WEIGHT lbs
											L/A	L/B	H			
FEKA 300 MA	7.4	10	2.2	11.7	6.9	13	14	2.8	3.7	1"1/4	11.3	8	17	16	0.9	10.1
FEKA 300 MNA	6.4	-	2.2	-	6.9	13	-	2.8	-	1"1/4	11.3	8	17	16	0.9	10.4
FEKA 600 MA	7.4	10	2.2	11.7	6.9	13.7	17.4	2.8	7.5	1"1/4	11.3	8	17	16	0.9	15.4
FEKA 600 MNA	6.4	-	2.2	-	6.9	13.7	-	2.8	-	1"1/4	11.3	8	17	16	0.9	15.4