



GoI Pumps Technology Company
Supply, Import, Export Water Pumps

HM Series Submersible Drainage Pump

60HZ





HM SERIES - Submersible Pump



Model Code

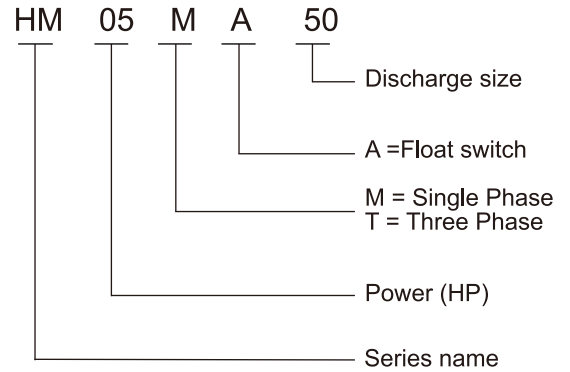

Applications

- Basement water removal
- Waste water drainage
- Water transfer
- Sump/effluent handling
- Dewatering
- Fish pond & fountain circulation
- Factory waste water handling

Motor Data

- Motor Type : 2 POLE , dry type
- Frequency : 60Hz
- Nominal Speed : 3450 rpm
- Insulation Class : F class (155°C)
- Enclosure Protection Class : IP 68
- Protection Device :
Thermal Protector (Single phase)
Overload Protector(Three phase)

Pump Data

- Impeller : Vortex Impeller
- Shaft Seal / Mechanical :
Double Seals
- Bearing :
Double-shielded Ball Bearing

Operation Conditions

- Fluid Temperature: 0 to 40°C (104°F)

Material

No.	Component	Material
1	Cable	SJTW/STOW
2	Handle	Nylon6+30GF
3	Motor cover	ADC-12
4	Bearing cap	SECC
5	Motor frame	ADC-12
6	M.Seal Bracket	FC200
7	Cable Base	Nylon6+30GF
8	Motor Shaft	AISI410
9	Mechanical seal	CA / CE, SIC/SIC
10	Oil Seal	NBR70
11	Impeller	TPU
12	Pump casing	FC200
13	Flange	FC200

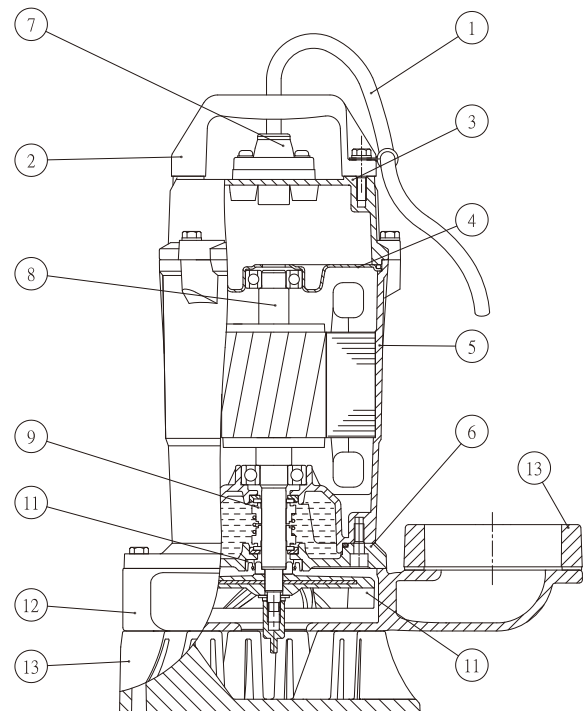



Performance Curves

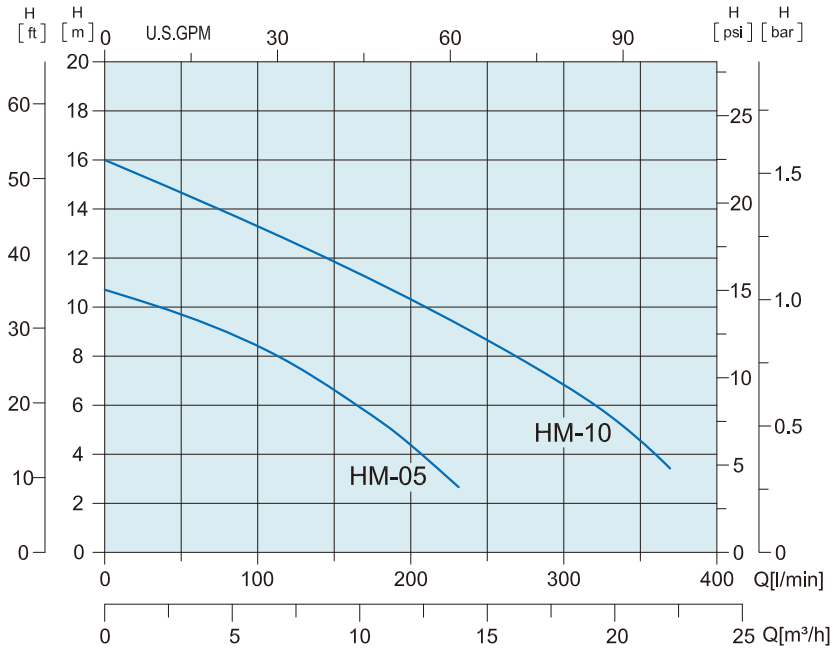

Technical Data

Single Phase

Model	Power		Current(A)		Capacitoret		Head		Flow		Discharge inch
	HP	Kw	110-127V	220-230V	110-127V UF / V	220-230V UF / V	Rated (M)	Max (M)	Rated (L/min)	Max (L/min)	
HM 05-M-50	0.5	0.37	5.6-4.9	2.6-2.5	50uF 250V	12uF 450V	7.0	11.9	140	230	2"
HM 05-MA-50											
HM 10-M-50	1.0	0.75	10.8-9.4	5.4-5.2	80uF 250V	20uF 450V	10.0	17.2	190	316	2"
HM 10-MA-50											
HM 10-M-80	1.0	0.75	10.8-9.4	5.4-5.2	80uF 250V	20uF 450V	10.0	17.2	190	316	3"
HM 10-MA-80											

Three Phase

Model	Power		Current(A)			Head		Flow		Discharge inch
	HP	Kw	220-230V	380-440V	460-480V	Rated (M)	Max (M)	Rated (L/min)	Max (L/min)	
HM 05-T-50	0.5	0.37	2.1-2.0	1.2-1.1	1.2-1.0	7.0	11.9	140	230	2"
HM 10-T-50	1.0	0.75	3.3-3.2	1.9-1.8	1.8-1.6	10.0	17.2	190	316	2"
HM 10-T-80	1.0	0.75	3.3-3.2	1.9-1.8	1.8-1.6	10.0	17.2	190	316	3"

Dimensions

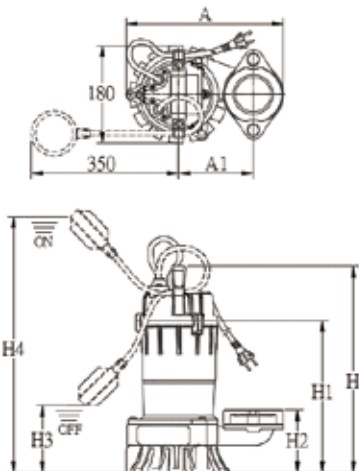

Model	Discharge[mm]							Solid Passage [mm]	Cable		N.W. [kg]
	H	H1	H2	H3	H4	A	A1		M	UL(AWG)	
HM 05-M-50	365	264	110	115	535	254	120	10	10	16AWGx3C	12.9
HM 05-MA-50	365	264	110	115	535	254	120	10	10	16AWGx3C	13.4
HM 10-M-50	380	279	116	130	550	285	135	10	10	16AWGx3C	15.1
HM 10-MA-50	380	279	116	130	550	285	135	10	10	16AWGx3C	15.6
HM 10-M-80	380	279	116	130	550	285	135	10	10	16AWGx3C	15.1
HM 10-MA-80	380	279	116	130	550	285	135	10	10	16AWGx3C	15.6
HM 05-T-50	365	264	110	-	-	254	120	10	10	16AWGx4C	11.9
HM 10-T-50	380	279	116	-	-	285	135	10	10	16AWGx4C	14.1
HM 10-T-80	380	279	116	-	-	285	135	10	10	16AWGx4C	14.1



Gol Pumps Technology Company

Supply, Import, Export Water Pumps

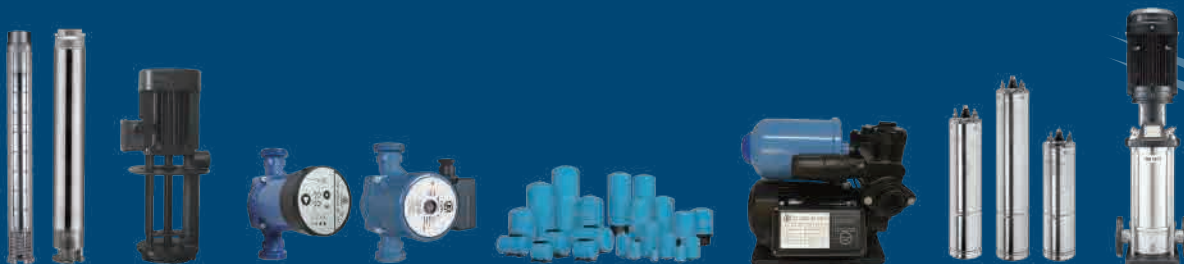

Gol Pumps Technology

www.golpumptechnology.com

Our Address: 6520 NW 77th CT, Miami FL 33166, USA

Sales DPT: +1 786 615 8984

After Sales Service: +1 786 452 9775

Fax: +1 786 615 7043

Email: info@golpumps.com

