

Pump Data

Brand :	Gol Pump		
Model :	GHM - 10 MA 50		
Head Rate:	33 FEET	Flow Rate:	50 GPM
Head Max:	56 FEET	Flow Max:	83 GPM
Head Min:	6 FEET	Flow Min :	5 GPM
RPM :	3450 rpm		
Normal Power P1 :	1 HP		
Fluid:	Water		
Fluid Temperature:	at about 25 °C.		
Density:	water 997 kg/m ³		
Fluid Viscosity:	8.90 × 10 ⁻⁴ Pa·s		
With Float switch	NONE		
Self Priming	Submersible		
Delivery size	2" NPT		
Suction size	With Strainer		
Made in :	TAIWAN		

Motor Data

Power P2:	*		
Power P1:	0.75 KW		
Phase (PH):	1		
Rate Voltage :	220 - 230V		
Capacitor Need :	20µf 450V		
Ferequency :	60 Hz		
Rated Speed (rpm):	3450 rpm		
Current (A):	5.4 - 5.2A		
Cos φ :	0.95		
Degree of Protection (IP):	IP 68		
Safety Protection Included:	F		
length of Cable :	10 M		
Kind of Plug :	*		
Ambient Temp :	40°C = 104°F		

Other Pump Data

Impeller Size (mm) :	*		
Pressuer Rating :	PN 16		
Min. Fluid Temp :	0°C = 0°F		
Max. Fluid Temp :	40°C = 104°F		
Ambient Temp :	40°C = 104°F		
Humidity % :	100%		

Special Specification

Installation status :	Ver		
Variable frequency :	NONE		
Solid Passage	10 mm		

Materials

Pump Body :	ADC 12		
Support:	FC 200		
Impeller	FC 25		
Mechanical Seal:	CA/CE * Sic/Sic		
Rubber	NBR 70		
Pump Shaft:	AISI 410		
Strainer	PVC		
outer cover:	Plastic		
Motor:	Stainless steel		

Shaft Seal

Type:	*		
Stationary Part	AISI 410		
Rotating Part	AISI 410		
Elastomer	NBR 70		

Pump and Motor specification optional

With Booster System	None		
With Complack	None		
Special Material	None		
Speccail Voltage	None		

Protection system required

External Flout switch	YES		
Minimum Starter	Starter SWT		

Performance curves

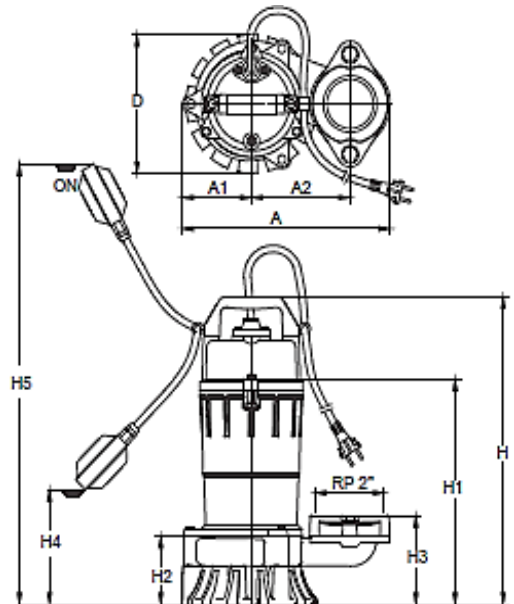
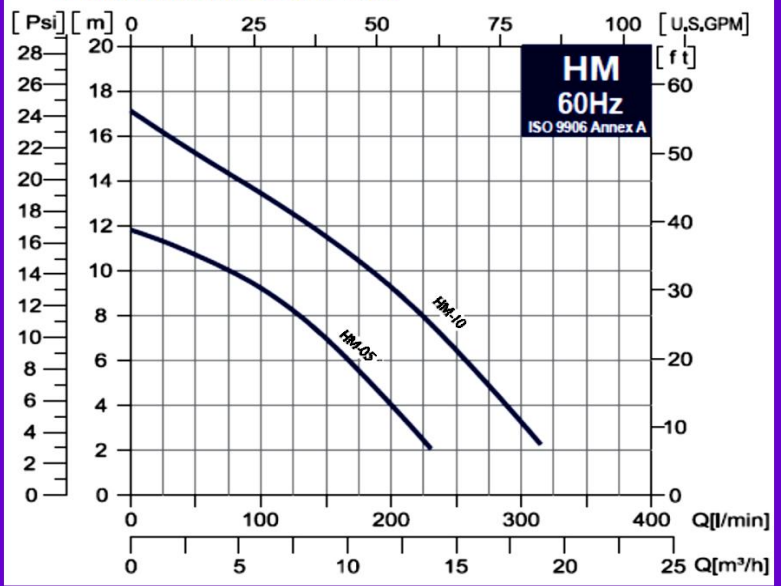

Weight : 15.1 Kg		Applicant:	Dimention in	
Standard Approve			mm	
CSA		Basement Water Removal , Waste Water Drainage , Water Transfer Sump / Effluent Handling , Dewatering , Fish Pond Fountain Circulation , Sewage Handling Factory Waste Water Handling	A	285
			A1	95
A2	135			
D	180			
H	380			
UL		H1	279	
		H2	90	
CE		H3	116	
		H4	130	
		H5	550	