



Technical Data

Vertical In-line Pump - EGM100-8020-04004

Creator:
Date:2025-02-06

Liquid						
	Pumped liquid	Clean water				
	Liquid temperature range	-15~85				
	Selected liquid temperature	20				
	Density	1000	kg/m ³			
	Kinematic viscosity	1	mm ² /s			
Technical						
	Pump type	EGM100-8020				
	Flow	400	us.gpm	Max.Flow	489.21	us.gpm
	Head	35	Ft	Min.flow	221.93	us.gpm
	Rated Speed	1750	rpm	Efficiency	77.7	%
	NPSH	1.9	m	Shaft Power	3.4	kW
	Inlet pressure		m	Max.operating pressure		m
	Shut off head	43.4	Ft	Rotation direction	clockwise	
	Impeller nom	214	mm	Actual impeller diameter	165.7	mm
Material						
	Casing	HT200				
	Impeller	HT200				
	Wear ring	HT250				
	Shaft	45#				
Shaft Seal						
	Model	MG1		Dimensions	32	mm
	Material	Carbon/SiC/viton				
Installation						
	Range of ambient temperature	-15~40°C				
	Maximum operating pressure	10 bar				
	Flange standard	GB/T17241.6				
	Pressure rating for connection	PN16				
	Pump Inlet	100				
	Pump Outlet	100				
Electrical data						
	Motor type					
	IE Efficiency class	IE2				
	Rated power	4.0kW				
	Mains frequency	60Hz				
	Motor mounting codes	V1				
	Rated voltage	380V				
	Rated current					
	Starting Current					
	Power factor					
	Rated Speed					
	Motor efficiency at full load	%				
	Brand					
	Number of poles	4				
	Insulation class (IEC 85)	F				
	Enclosure class (IEC 34-5)	IP55				
Weight						
	pump	76	kg			
	Motor		kg			
	Total weight	76	kg			



Technical Data

Vertical In-line Pump - EGM100-8020-04004

Creator:
Date:2025-02-06

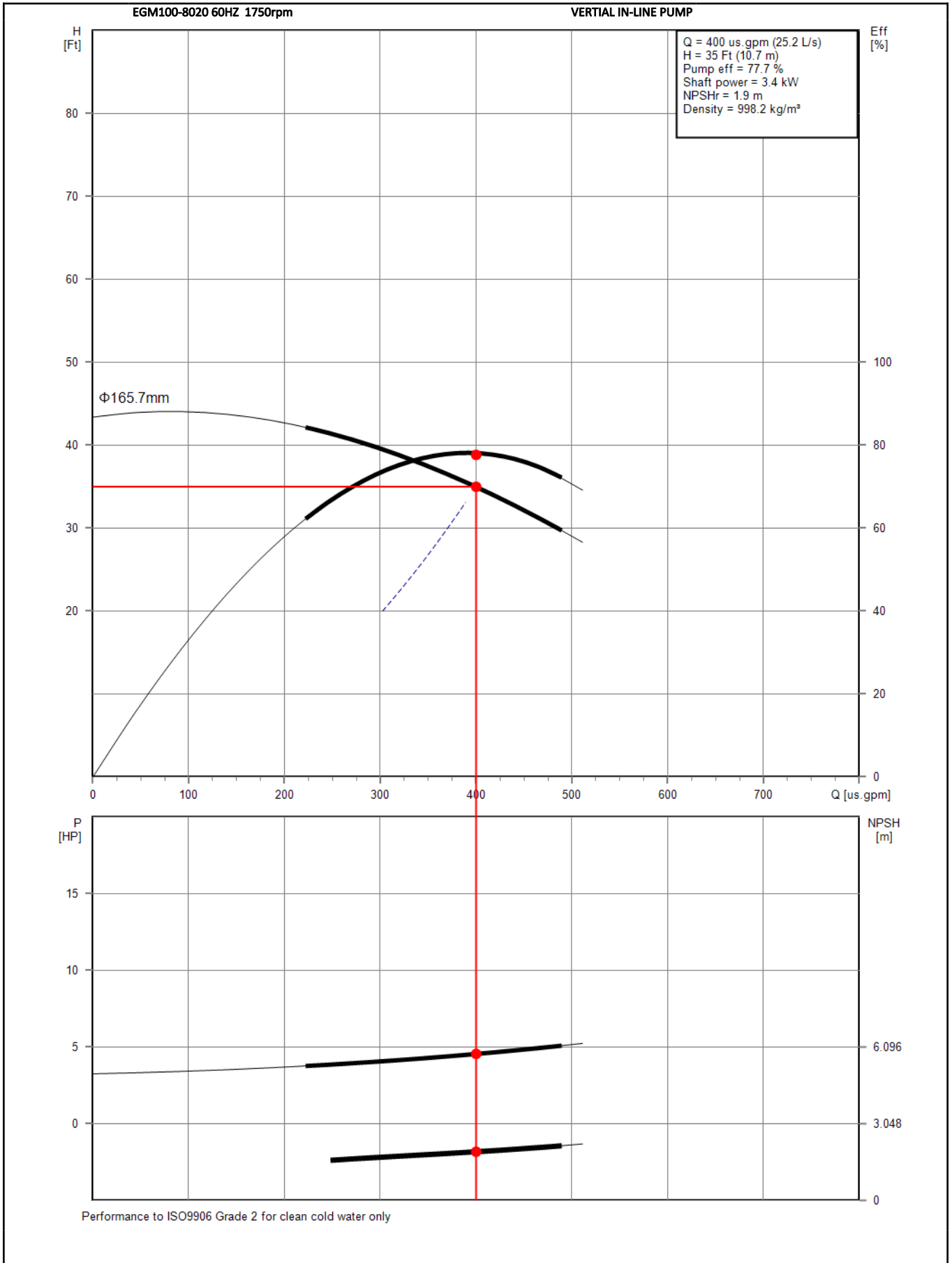



Technical Data

Vertical In-line Pump - EGM100-8020-04004

Creator:
Date:2025-02-06

Liquid	Pumped liquid	Clean water	
	Liquid temperature range	-15~85	
	Selected liquid temperature	20	
	Density	1000	kg/m ³
	Kinematic viscosity	1	mm ² /s

Technical	Model	EGM100-8020	
	Flow	400	us.gpm
	Head	35	Ft
	Rated Speed	1750	rpm
	NPSH	1.9	m
	Inlet pressure		m
	Shut off head	43.4	Ft
	Impeller nom	214	mm

Material	Casing	HT200
	Impeller	HT200
	Wear ring	HT250
	Shaft	45#

Shaft Seal	Model	MG1	
	Dimensions	32	mm
	Material		

Installation	Range of ambient temperature	-15~40°C
	Maximum operating pressure	10 bar
	Flange standard	GB/T17241.6
	Pressure rating for connection	PN16
	Pump Inlet	100
	Pump Outlet	100

Motor	Motor type	
	IE Efficiency class	IE2
	Rated power	4.0kW
	Mains frequency	60Hz
	Motor mounting codes	V1
	Rated voltage	380V
	Rated current	
	Starting Current	
	Power factor	
	Rated Speed	
	Motor efficiency at full load	%
	Brand	
	Number of poles	4
	Insulation class (IEC 85)	F
Enclosure class (IEC 34-5)	IP55	

Weight	pump	76	Kg
	Motor		Kg
	Total weight	76	Kg

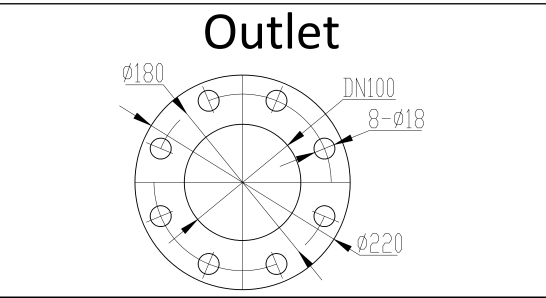
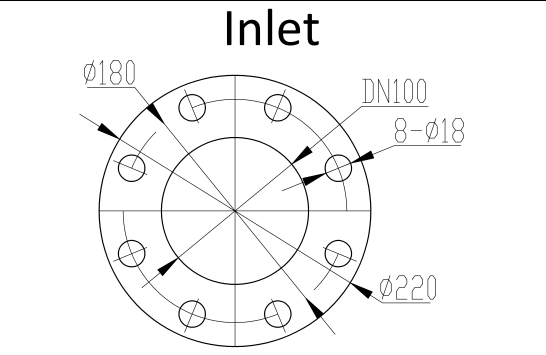
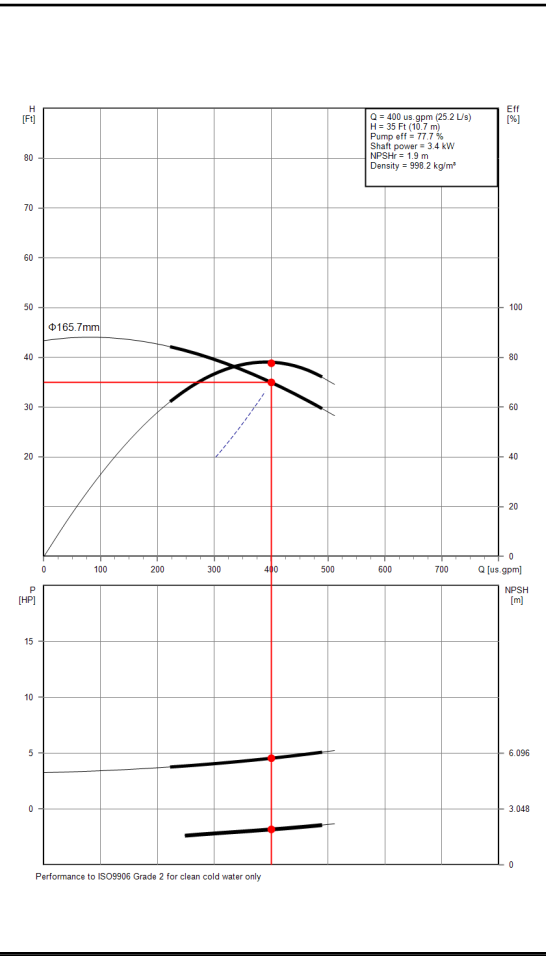



Technical Data

Vertical In-line Pump - EGM100-8020-04004

Creator:
Date:2025-02-06

Flange: ANSI Class 125

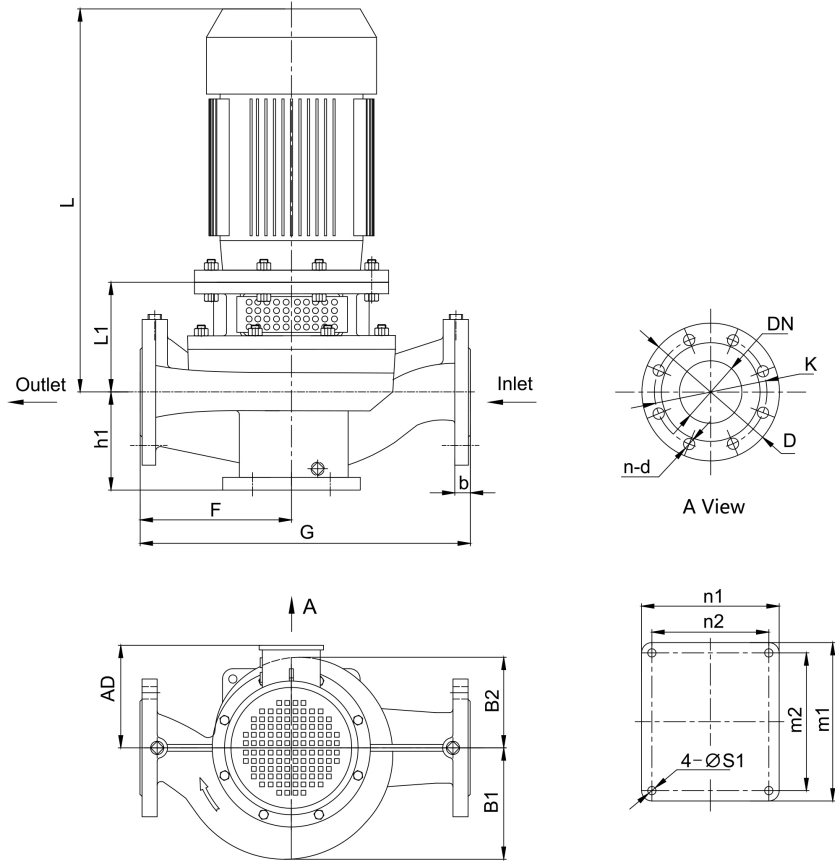

Pump Installation Size (inch)

h1	L1	F	G	L	AD	B1	B2	n2 x m2	n1 x m1	S1	DN	D	K	n - d	b
7	7	11	24	20	7	7	8	7x8	8x9	0.6	4	9	7	8 - ϕ 0.7	-