

X-SMART 400A

Dewatering Pump

60 Hz

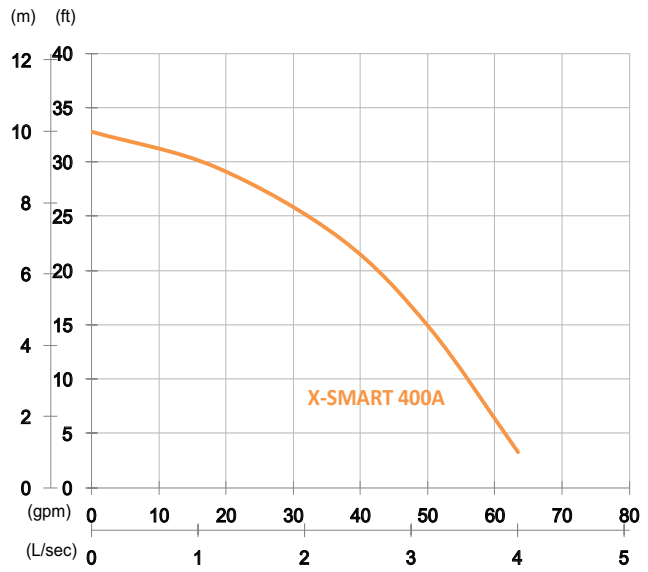

Shaft Speed : 3450 rpm

Outlet : 50mm, 2in

| OUTPUT | HEAD | FLOW |
|--------|------------------|-------------------------|
| 0.4 kW | Rated : 7m, 23ft | Rated : 2.3 L/s, 37 gpm |
| 0.5 HP | Max : 10m, 33ft | Max : 4 L/s, 63 gpm |

Solid Passage : 5.5mm, 0.2in

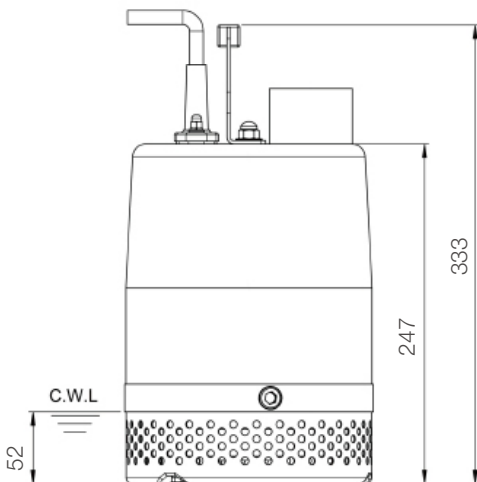
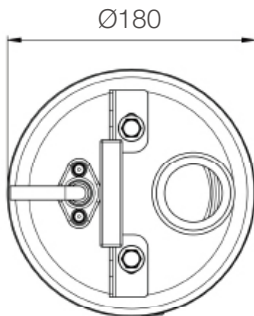

unit : mm

Weight : 13kg / 29 lbs

| | | |
|-------------------------|-------------------------------------|--------------------------|
| Pump Type | Electric Submersible Pumps | |
| | 1-Phase, 110V | |
| Motor | Type | Induction Motor |
| | Poles | 2 Pole |
| | Insulation | Class F |
| | Protector | Circle Thermal Protector |
| | Starter | 1-Phase · Capacitor-Run |
| Lubricant | Food Grade (ISO VG32) | |
| Impeller Type | Opened | |
| Shaft Seal | Double Mechanical Seal | |
| | Silicon Carbide VS Ceramic / Carbon | |
| Bearings | C3 Shielded ball bearings | |
| Cable | PVC (CSA Certified) / H07RN-F | |
| | 6m (20ft) or longer upon request. | |
| Materials | Pump Casing | Stainless Steel |
| | Impeller | Stainless Steel |
| | Motor Frame | Stainless Steel |
| | Motor Shaft | Stainless Steel |
| | Strainer | Stainless Steel |
| Max. Liquid Temperature | 40°C (104°F) | |
| Max. Submersion Depth | 20m (66ft) | |
| pH Range | pH 5 - pH 8 | |