

TANK 3110

60 Hz

High Chrome Dewatering Pump

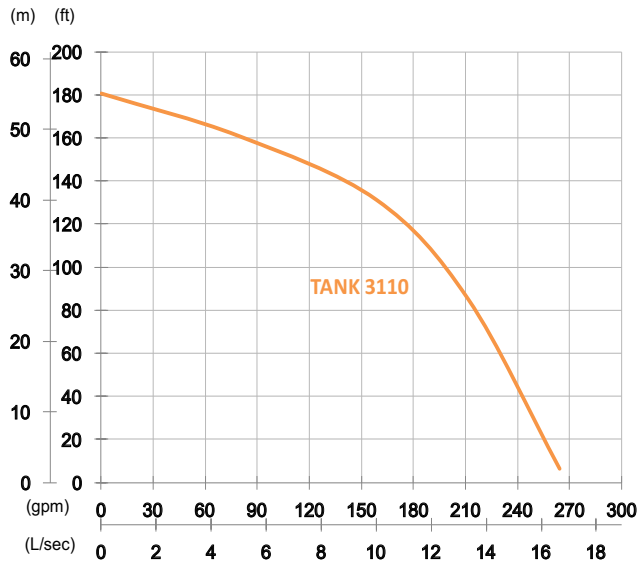

Shaft Speed : 3450 rpm

Outlet : 80mm, 3in

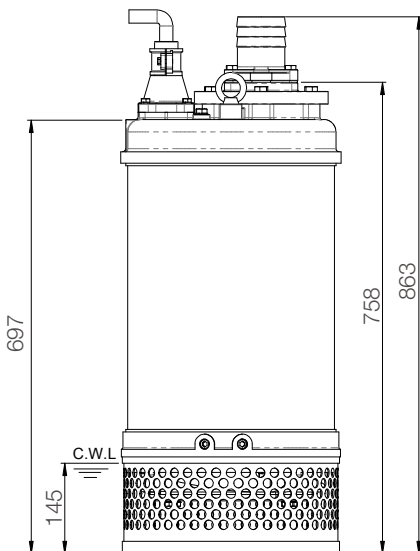
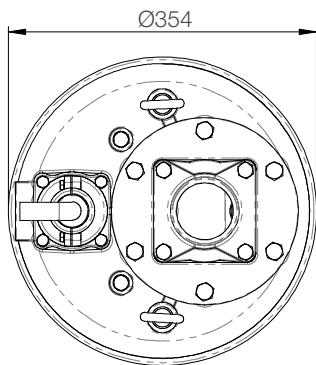

unit : mm

Weight : 135kg / 298 lbs

OUTPUT	HEAD	FLOW
11 kW	Rated : 40m, 131ft	Rated : 10 L/s, 158 gpm
15 HP	Max : 55m, 180ft	Max : 16.7 L/s, 264 gpm

Solid Passage : 10mm, 0.4in

Pump Type		Electric Submersible Pumps
		3-Phase, 220V or 460V
Motor	Type	Induction Motor
	Poles	2 Pole
	Insulation	Class F
	Protector	Circle Thermal Protector
	Starter	3-Phase · D.O.L.
Lubricant		Food Grade (ISO VG32)
Impeller Type		Opened
Shaft Seal		Double Mechanical Seal
		Silicon Carbide VS Ceramic / Carbon
Bearings		C3 Shielded ball bearings
Cable		PVC (CSA Certified) / H07BQ-F
		10m (33ft) or longer upon request.
Materials	Pump Casing	Gray Iron
	Impeller	Chromium Iron
	Motor Frame	Gray Iron
	Motor Shaft	Stainless Steel
	Strainer	Stainless Steel
Max. Liquid Temperature		40°C (104°F)
Max. Submersion Depth		20m (66ft)
pH Range		pH 5 - pH 8